

General Description

The Sanrise SRC65R220BS is a high voltage power MOSFET, fabricated using advanced super junction technology. The resulting device has extremely low on resistance, low gate charge and fast switching time, making it especially suitable for applications which require superior power density and outstanding efficiency.

The SRC65R220BS break down voltage is 650V and it has a high rugged avalanche characteristics.

The SRC65R220BS is available in TO-220F , TO-220C, TO-247and TO-263-2 packages.

Features

- Ultra Low $R_{DS(ON)} = 220m\Omega @ V_{GS} = 10V$.
- Ultra Low Gate Charge, $Q_g=38.4nC$ typ.
- Intrinsic Fast-Recovery Body Diode
- Fast switching capability
- Robust design with better EAS performance
- Non-automotive Qualified
- Ultra-fast body diode

Application

- UPS, Inverter, etc
- Solar
- High Power AC/DC Power Supply

Ordering Information

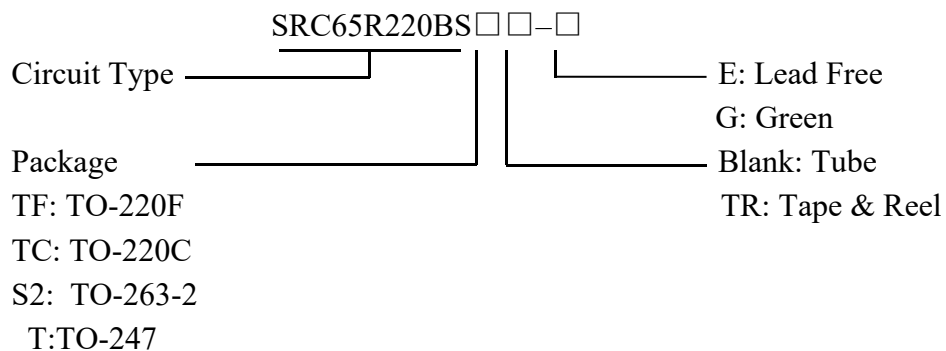

Symbol

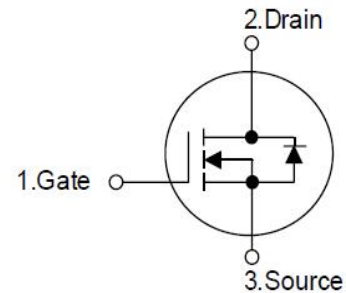

Figure 1 Symbol of SRC65R220BS

Package Type

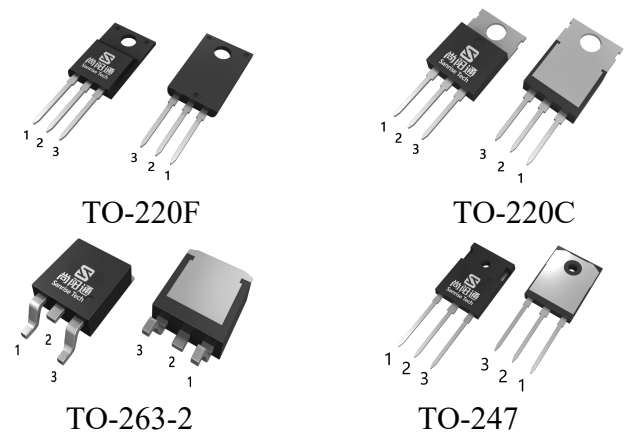

Figure 2 Package Types of SRC65R220BS

Package	Part Number		Marking ID		Packing Type
	Lead Free	Green	Lead Free	Green	
TO-220F	SRC65R220BSTF-E	SRC65R220BSTF-G	SRC65R220BSTFE	SRC65R220BSTFG	Tube
TO-220C	SRC65R220BSTC-E	SRC65R220BSTC-G	SRC65R220BSTCE	SRC65R220BSTCG	Tube
TO-263-2	SRC65R220BSS2TR-E	SRC65R220BSS2TR-G	SRC65R220BSS2E	SRC65R220BSS2G	Tape & Reel
TO-247	SRC65R220BST-E	SRC65R220BST-G	SRC65R220BSTE	SRC65R220BSTG	Tube

Absolute Maximum Ratings

Parameter		Symbol	Rating	Unit
Drain-Source Voltage (Note2)		V_{DSS}	650	V
Gate-Source Voltage		V_{GSS}	±30	V
Gate-Source Voltage(dynamic),AC($f > 1\text{Hz}$)		V_{GSS}	±30	V
Power Dissipation($T_C=25^\circ\text{C}$,TO-220C,TO-263-2,TO-247)		P_{tot}	179	W
Power Dissipation($T_C=25^\circ\text{C}$,TO-220F)		P_{tot}	34	W
Continuous Drain Current	$T_C=25^\circ\text{C}$	I_D	21.2	A
	$T_C=100^\circ\text{C}$		13.4	
	$T_C=125^\circ\text{C}$		9.5	
Pulsed Drain Current (Note 3)		I_{DM}	63	A
Avalanche Energy, Single Pulse (Note 4)		E_{AS}	210	mJ
Avalanche Energy, Repetitive (Note 3)		E_{AR}	0.7	mJ
Avalanche Current, Repetitive (Note 3)		I_{AR}	2.5	A
Continuous Diode Forward Current		I_S	21.2	A
Diode Pulse Current		$I_{S,PULSE}$	64	A
MOSFET dv/dt Ruggedness, $V_{DS} \leq 480\text{V}$		dv/dt	50	V/ns
Operating Junction Temperature		T_J	150	°C
Storage Temperature		T_{STG}	-55 to 150	°C
Lead Temperature (Soldering, 10 sec)		T_{LEAD}	260	°C

Note:

1. Absolute maximum ratings are those values beyond which the device could be permanently damaged. Absolute maximum ratings are stress ratings only and functional device operation is not implied.
2. For voltage spike during switching.
3. Repetitive Rating: Pulse width limited by maximum junction temperature
4. $I_{AS} = 2.5\text{A}$, $V_{DD} = 60\text{V}$, $R_G = 25\Omega$, Starting $T_J = 25^\circ\text{C}$

Thermal characteristics

Parameter		Symbol	Min	Typ	Max	Unit
Thermal resistance, Junction-to-Case	TO-220F	R_{thJC}			3.6	°C /W
	TO-220C				0.7	
	TO-263-2				0.7	
	TO-247				0.7	
Thermal resistance, Junction-to-Ambient	TO-220F	R_{thJA}			80	°C /W
	TO-220C				62	
	TO-263-2				62	
	TO-247				62	

Electrical Characteristics

$T_J = 25\text{ }^\circ\text{C}$, unless otherwise specified.

Parameter	Symbol	Test Conditions	Min	Typ	Max	Unit
Drain-Source Breakdown Voltage	BV_{DSS}	$V_{GS}=0V, I_D=250\mu A$	650			V
Zero Gate Voltage Drain Current	I_{DSS}	$V_{DS}=650V, V_{GS}=0V$			10	μA
Gate-Body Leakage Current	Forward	$I_{GSSF}, V_{GS}=30V, V_{DS}=0V$			100	nA
	Reverse	$I_{GSSR}, V_{GS}=-30V, V_{DS}=0V$			-1.0	μA
Gate Threshold Voltage	$V_{GS(TH)}$	$V_{DS}=V_{GS}, I_D=250\mu A$	2.3	3.3	4.3	V
Static Drain-Source On-Resistance	$R_{DS(ON)}$	$V_{GS}=10V, I_D=10.0A$		170	220	mΩ
Gate Resistance	R_G	f=1MHz, Open Drain		1.7		Ω
Dynamic Characteristics						
Input Capacitance	C_{ISS}	$V_{DS}=50V, V_{GS}=0V, f=1MHz$		1660		pF
Output Capacitance	C_{OSS}			110		
Reverse Transfer Capacitance	C_{RSS}			22		
Effective output capacitance, energy related ^{NOTE5}	$C_{O(er)}$	$V_{GS}=0V, V_{DS}=0\dots 480V$		71		pF
Effective output capacitance, time related ^{NOTE6}	$C_{O(tr)}$			301		
Turn-on Delay Time	$t_{d(on)}$	$V_{DD}=400V, I_D=10.0A, R_G=3.4\Omega, V_{GS}=10V$		11		ns
Rise Time	t_r			10		
Turn-off Delay Time	$t_{d(off)}$			76		
Fall Time	t_f			8		
Gate Charge Characteristics						
Gate to Source Charge	Q_{gs}	$V_{DD}=480V, I_D=10.0A, V_{GS}=0 \text{ to } 10V$		10.8		nC
Gate to Drain Charge	Q_{gd}			12.3		
Gate Charge Total	Q_g			38.4		
Gate Plateau Voltage	$V_{plateau}$			5.4		V
Reverse Diode Characteristics						
Drain-Source Diode Forward Voltage	V_{SD}	$V_{GS}=0V, I_{SD}=10.0A$		0.87	1.1	V
Reverse Recovery Time	t_{rr}	$V_R=400V, I_F=10.0A, dI_F/dt=100.0A/us$		122		ns
Reverse Recovery Charge	Q_{rr}			0.78		μC
Peak Reverse Recovery Current	I_{rrm}			10.6		A

Note:

- $C_{O(er)}$ is a fixed capacitance that gives the same stored energy as C_{OSS} while V_{DS} is rising from 0 to 480V
- $C_{O(tr)}$ is a fixed capacitance that gives the same charging time as C_{OSS} while V_{DS} is rising from 0 to 480 V

Typical Performance Characteristics

<p>Figure 3: Power Dissipation</p>  <p>$P_{tot} = f(T_c)$</p>	<p>Figure 4: Max. Transient Thermal Impedance</p>  <p>$Z_{th(jc)} = f(t_p)$; parameter: $D = t_p / T$</p>
<p>Figure 5: Safe Operating Area</p>  <p>$I_D = f(V_{DS})$; $T_c = 25^\circ\text{C}$; $V_{GS} > 7\text{V}$; parameter t_p</p>	<p>Figure 6: Safe Operating Area</p>  <p>$I_D = f(V_{DS})$; $T_c = 80^\circ\text{C}$; $V_{GS} > 7\text{V}$; parameter t_p</p>

Figure 7: Typ. Output Characteristics

 $I_D = f(V_{DS}); T_j = 25^\circ\text{C}; \text{parameter: } V_{GS}$
Figure 8: Typ. Output Characteristics

 $I_D = f(V_{DS}); T_j = 125^\circ\text{C}; \text{parameter: } V_{GS}$
Figure 9: Typ. Drain-Source On-State Resistance

 $R_{DS(ON)} = f(I_D); T_j = 125^\circ\text{C}; \text{parameter: } V_{GS}$
Figure 10: Typ. Drain-Source On-State Resistance

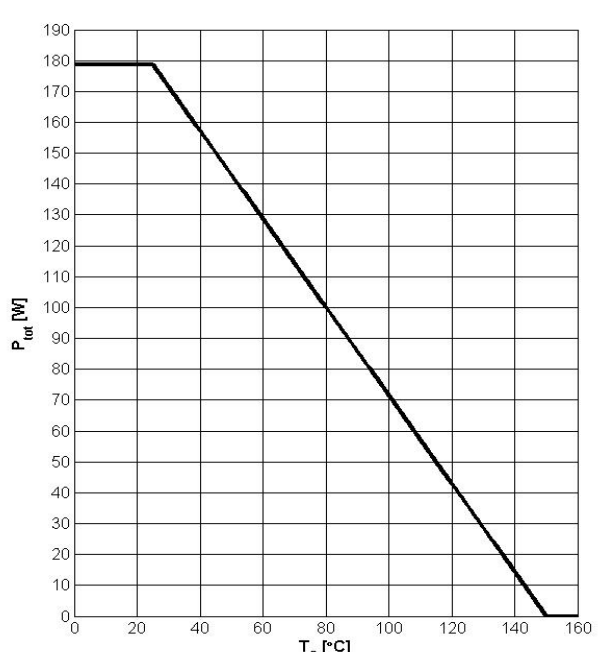
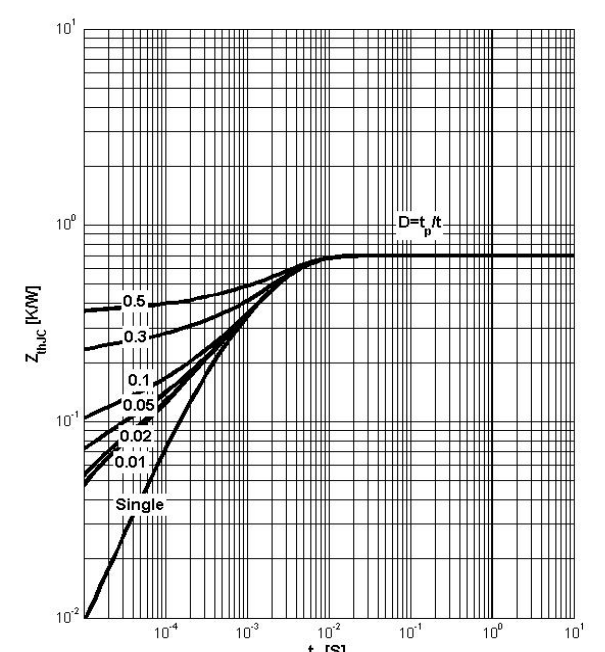
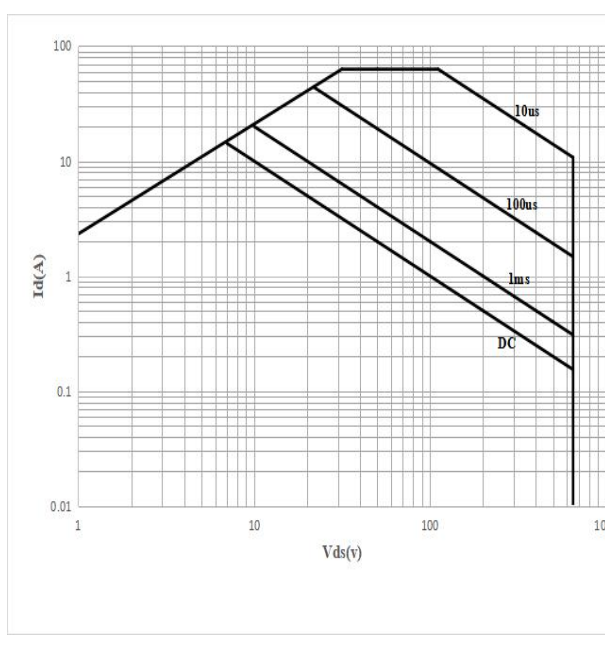
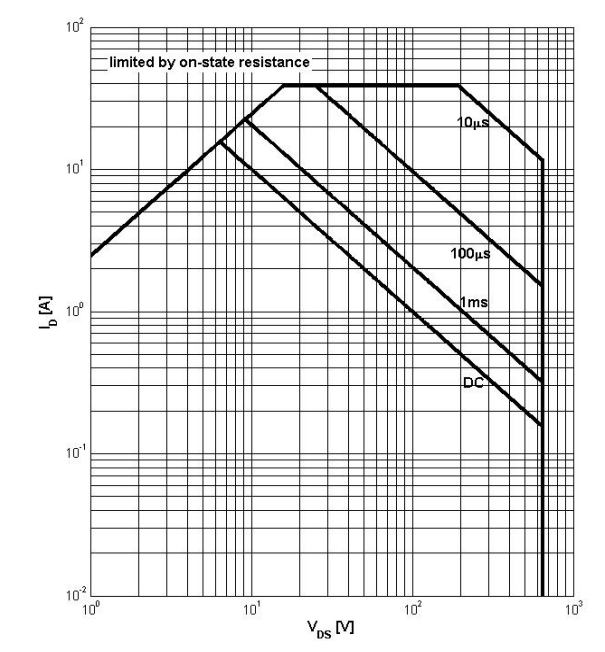
 $R_{DS(ON)} = f(T_j); I_D = 10\text{A}; V_{GS} = 10\text{V}$

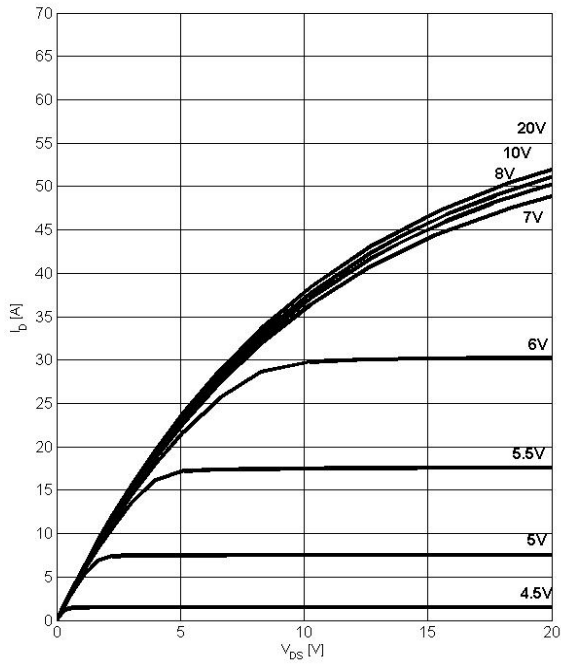
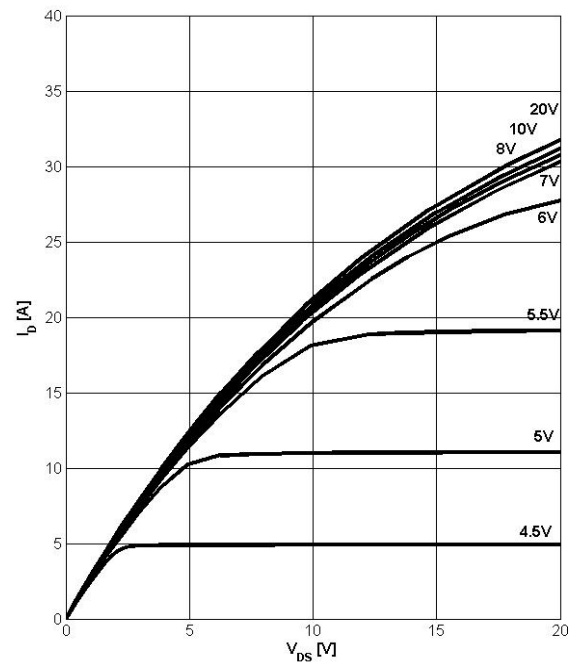
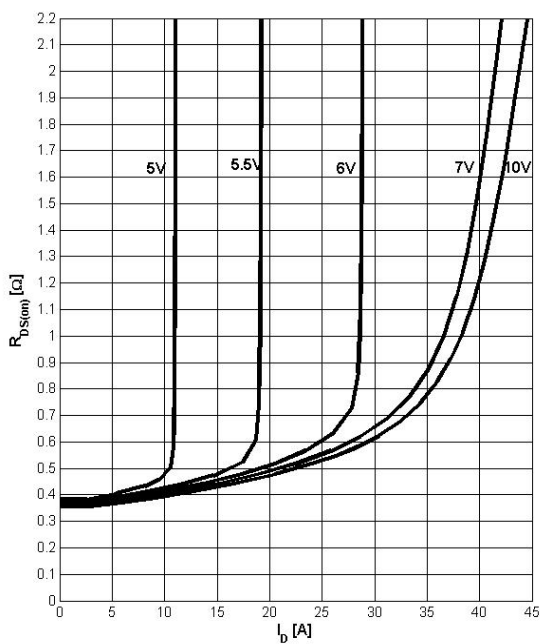
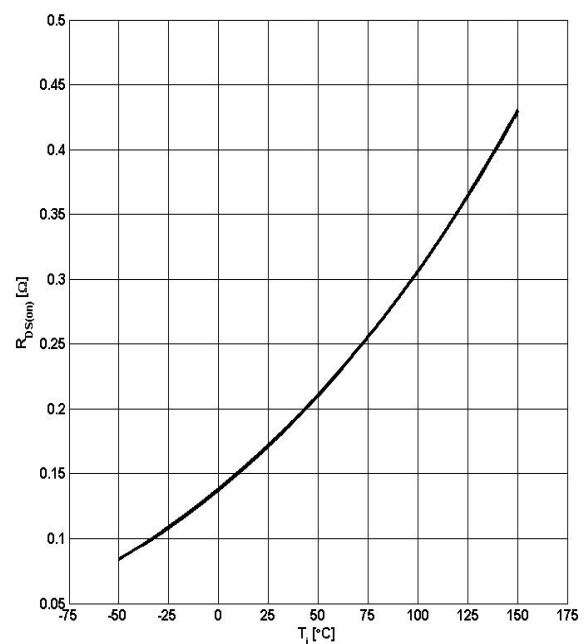
Figure 11: Typ. Transfer Characteristics

 $I_D = f(V_{GS}); V_{DS} = 20V$
Figure 12: Typ. Gate Charge

 $V_{GS} = f(Q_{gate}), I_D = 10A \text{ pulsed}$
Figure 13: Drain-Source Breakdown Voltage

 Minimum $V_{BR(DSS)} = f(T_j); I_D = 10mA$
Figure 14: Forward Characteristics of Reverse Diode

 $I_F = f(V_{SD}); \text{parameter: } T_j$

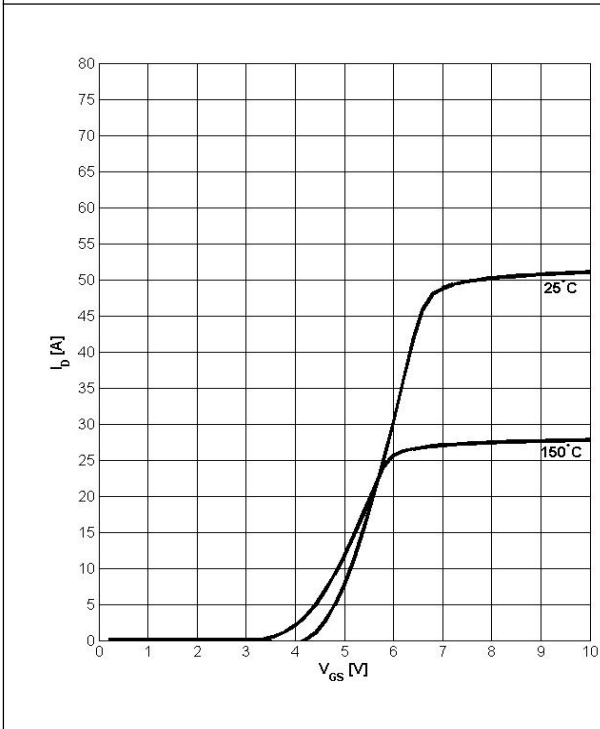
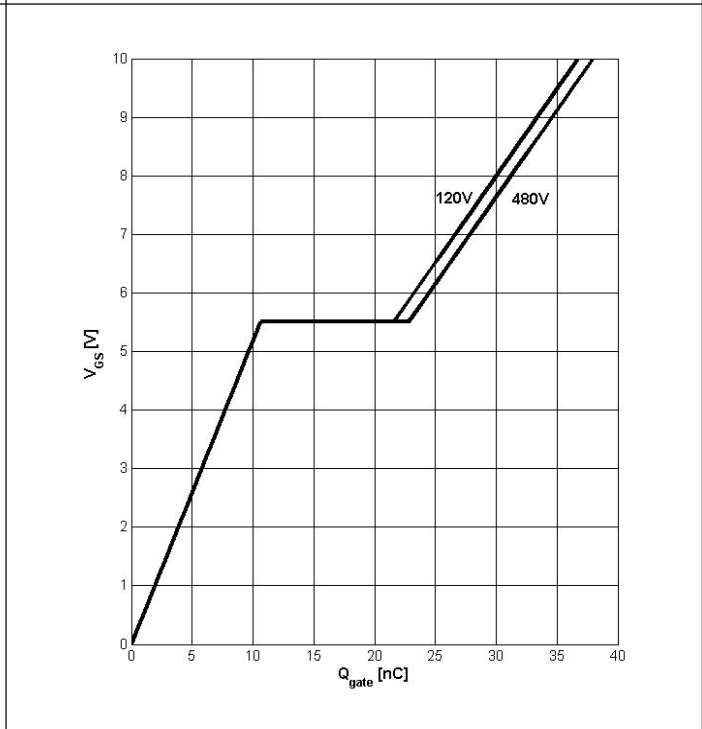
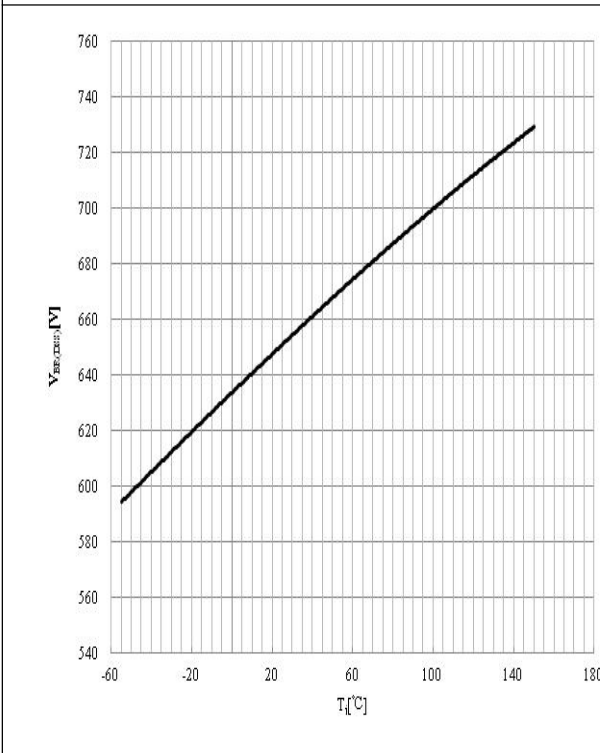
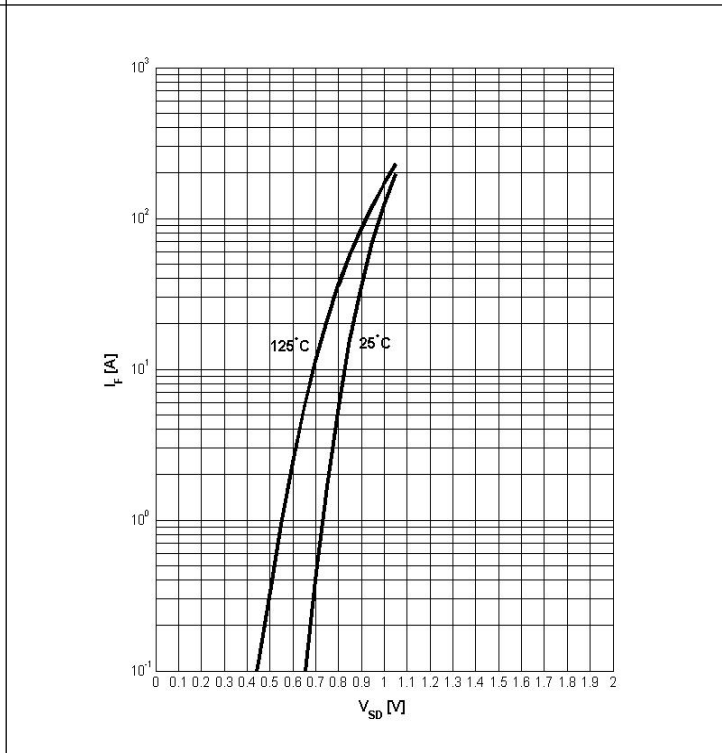
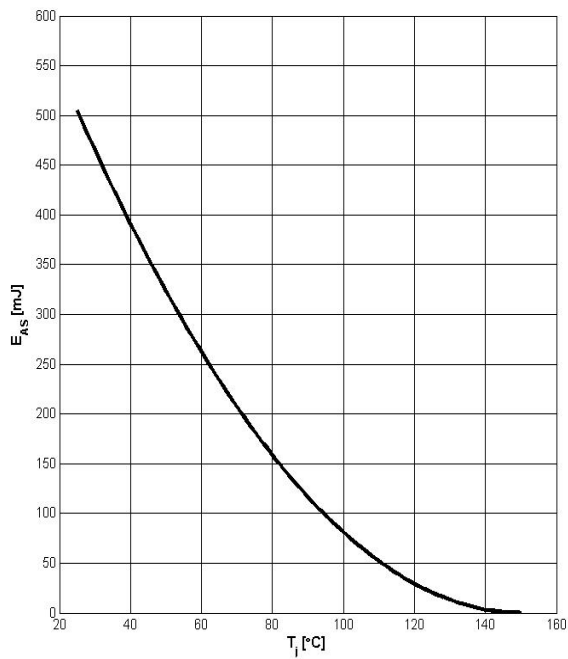
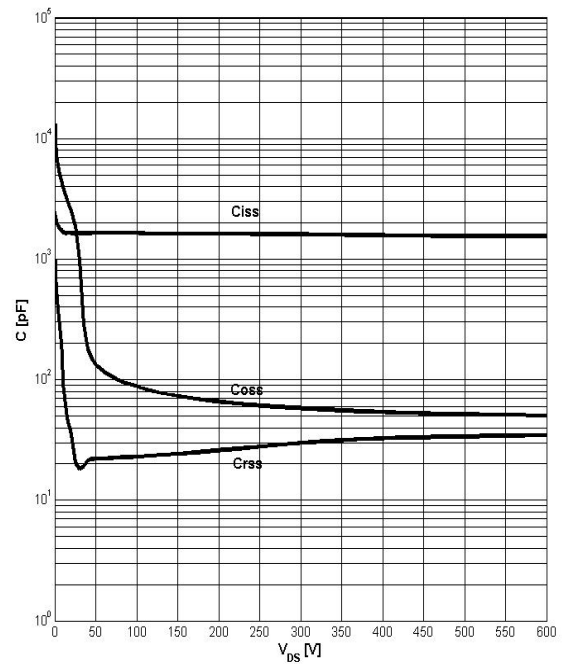
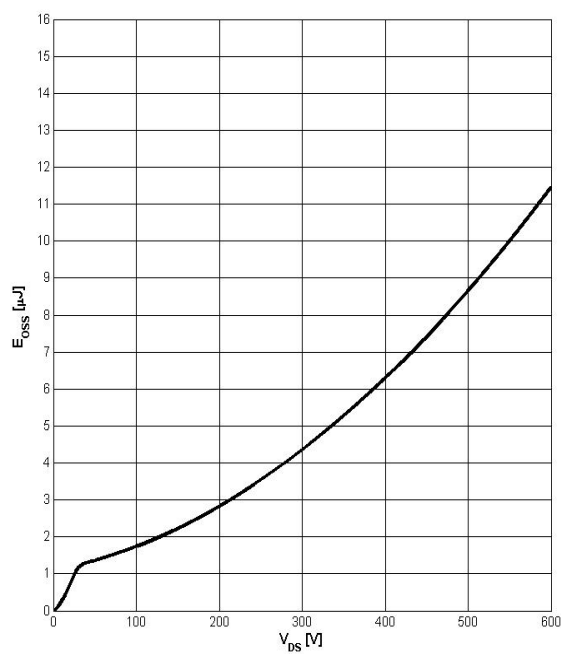
Figure 15: Avalanche Energy

$$E_{AS}=f(T_j); I_D=3.6A; V_{DD}=60V$$

Figure 16: Typ. Capacitances

$$C=f(V_{DS}); V_{GS}=0; f=1MHz$$

Figure 17: Coss Stored Energy

$$E_{oss}=f(V_{DS})$$

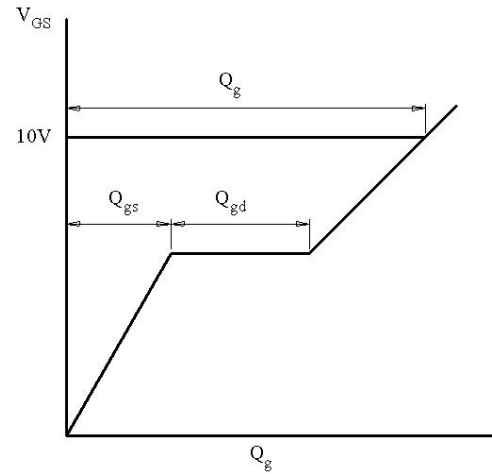
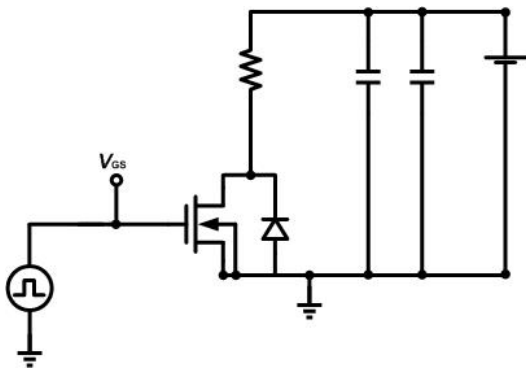
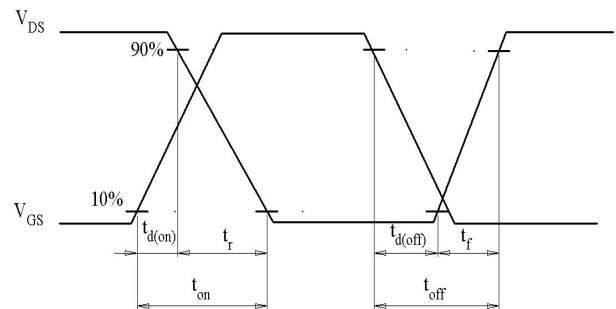
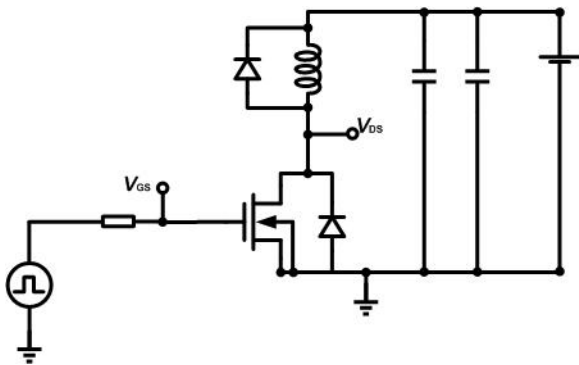
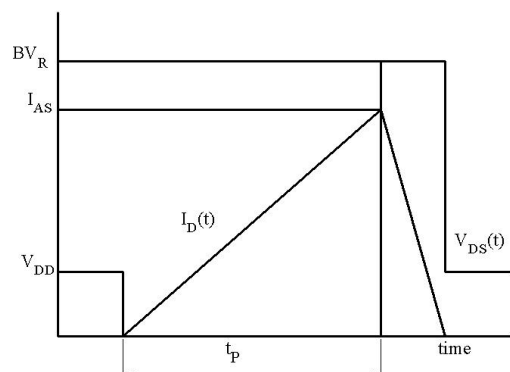
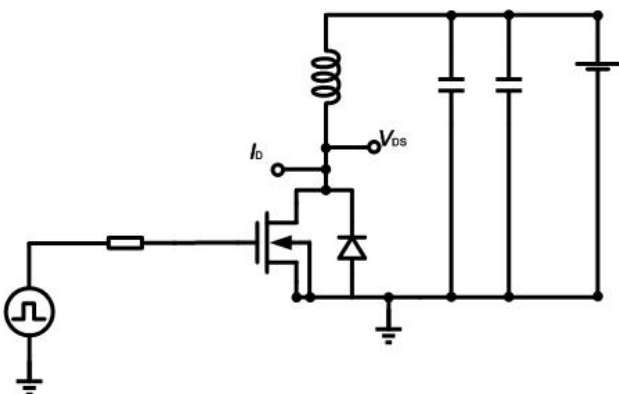
Test Circuits
1. Gate Charge Test Circuit & Waveform

2. Switch Time Test Circuit

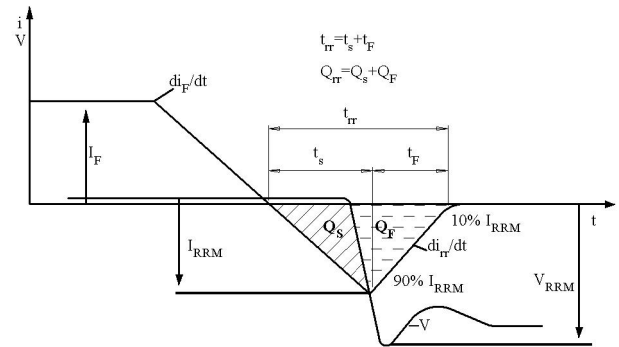
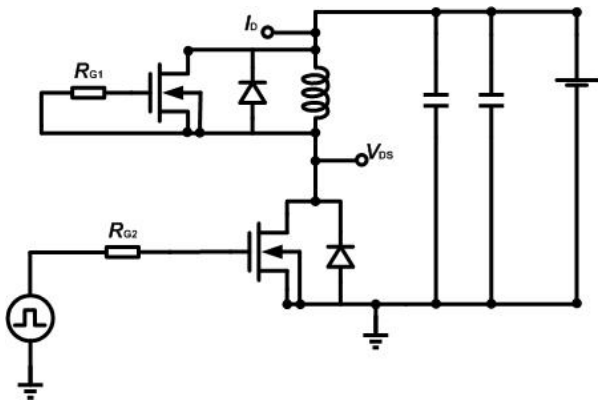
3. Unclaimed Inductive Switching Test Circuit & Waveforms

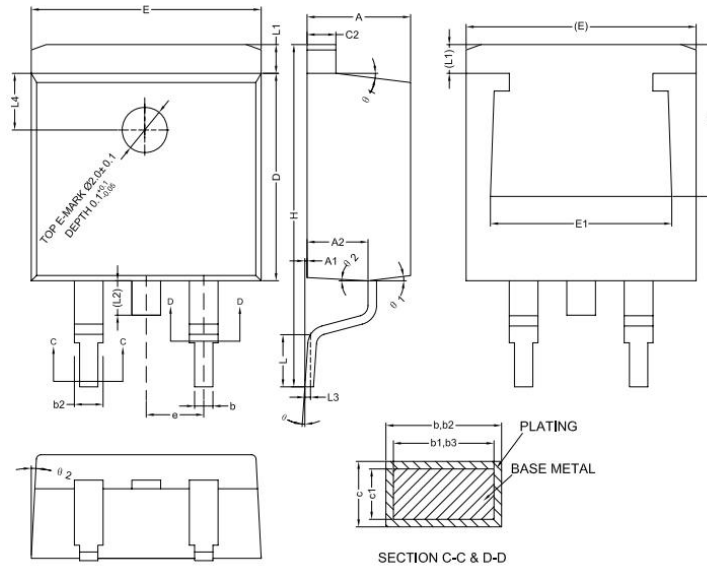
4. Test Circuit and Waveform for Diode Characteristics



Mechanical Dimensions
TO-263-2 (Package 1)
Unit: mm

Symbol	Dimensions(mm)		
	Min.	Typ.	Max.
A	4.40	4.57	4.70
A1	0.00	0.10	0.25
A2	2.59	2.69	2.79
b	0.77	-	0.90
b1	0.76	0.81	0.86
b2	1.23	-	1.36
b3	1.22	1.27	1.32
c	0.34	-	0.47
c1	0.33	0.38	0.43
c2	1.22	-	1.32
D	9.05	9.15	9.25
D1	6.60	-	-
E	10.06	10.16	10.26
E1	7.80	-	8.20
e	2.54(BSC)		
H	14.70	15.10	15.50
L	2.00	2.30	2.60
L1	1.17	1.27	1.40
L2	-	-	1.75
L3	0.25BSC		
L4	2.00REF		
θ	0°	-	8°
θ1	5°	7°	9°
θ2	1°	3°	5°

Mechanical Dimensions
TO-263-2 (Package 2)

Unit: mm

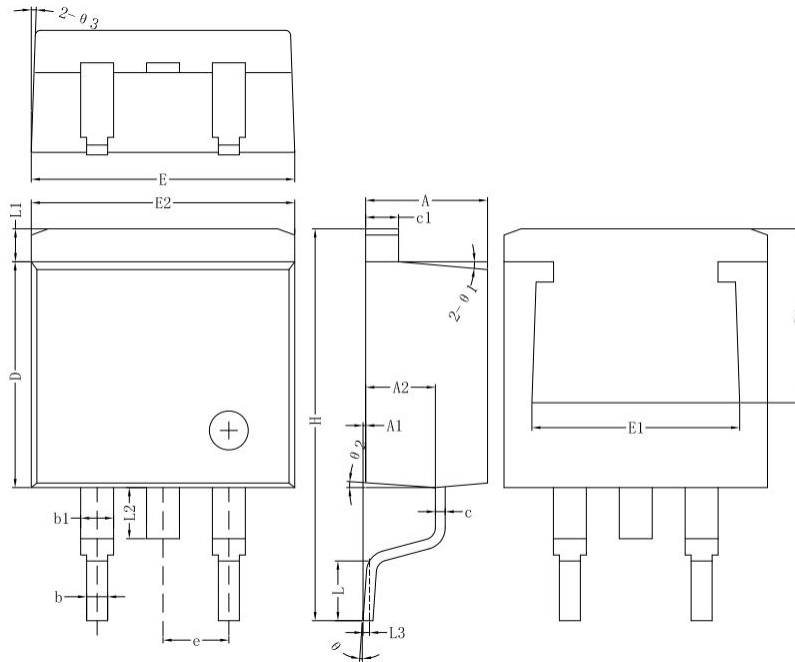

Symbol	Dimensions(mm)		
	Min.	Typ.	Max.
A	4.55	4.70	4.85
A1	0.00	0.10	0.25
A2	2.59	2.69	2.89
b	0.71	0.81	0.96
b1	-	1.27	-
c	0.36	0.38	0.61
c1	1.17	1.27	1.37
D	8.55	8.70	8.85
D1	-	7.2	-
E	10.01	10.16	10.31
E1	-	7.80	-
E2	9.98	10.08	10.18
e	-	2.54	-
H	14.70	15.10	15.50
L	2.00	2.30	2.70
L1	1.17	1.27	1.40
L2	-	-	2.20
L3	-	0.25BSC	-
θ	0°	-	8°
θ1		5°	
θ2		4°	
θ3		4°	

Mechanical Dimensions
TO-263-2 (Package 3)

Unit: mm

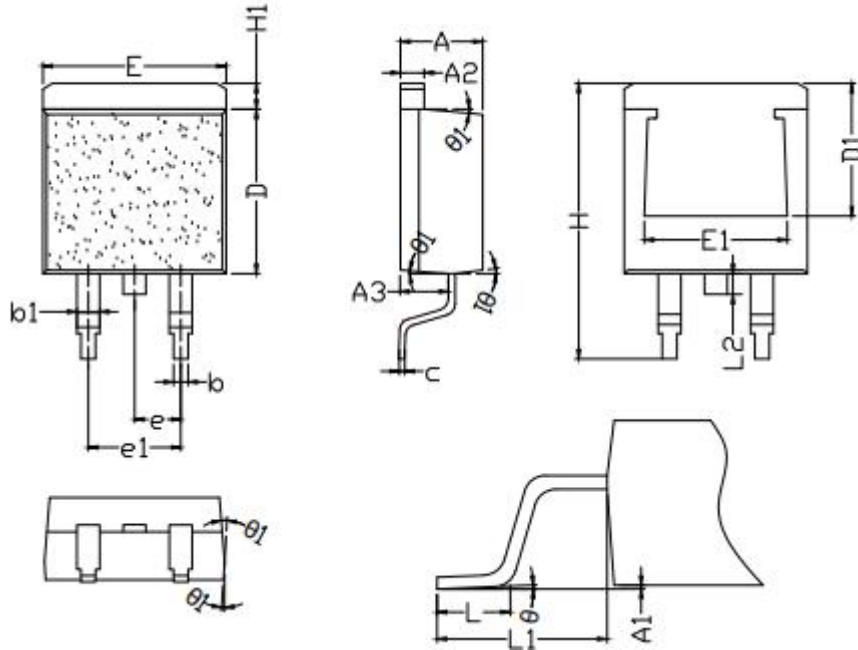

Symbol	Dimensions(mm)		
	Min.	Typ.	Max.
A	4.42	4.52	4.62
A1	0.00	0.10	0.25
A2	1.24	1.27	1.32
A3	2.50	2.60	2.70
b	0.77	0.81	0.84
b1	1.23	1.28	1.41
c	0.33	0.38	0.43
D	8.80	8.95	9.10
D1	7.2REF		
E	9.92	10.07	10.22
E1	7.85REF		
e	2.50	2.54	2.58
e1	5.08REF		
H	14.80	15.10	15.30
H1	1.12	1.28	1.42
L	2.10	2.23	2.36
L1	4.55	4.75	4.95
L2	1.10	1.30	1.50
θ	0°	2°	5°
θ1	3°	-	5°

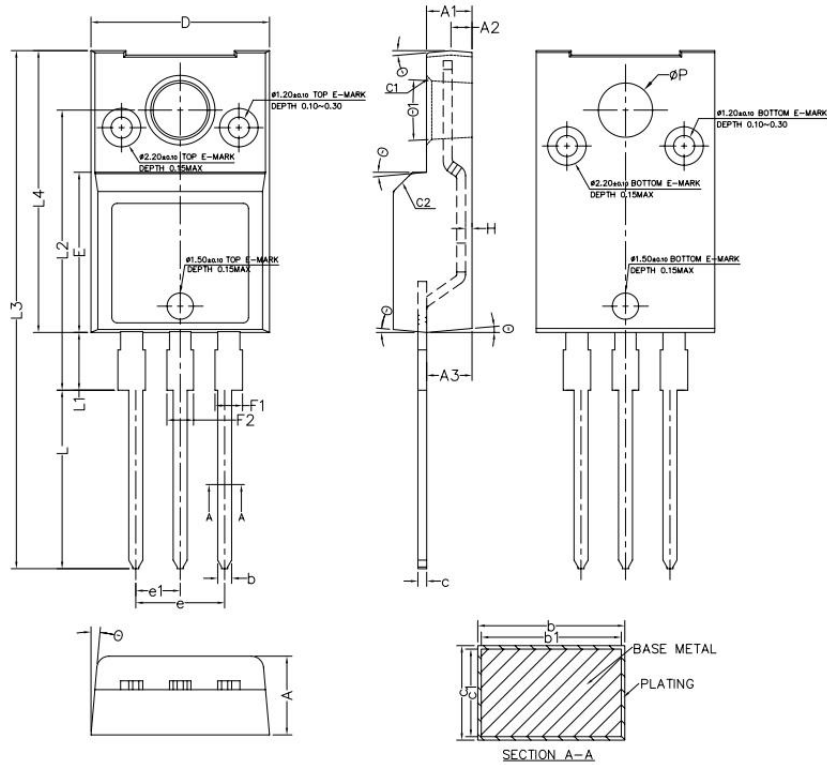
Mechanical Dimensions
TO-220F (Package 1)
Unit: mm

Symbol	Dimensions(mm)		
	Min.	Typ.	Max.
A	4.40	4.50	4.60
A1	2.50	2.60	2.70
A2	1.10	1.20	1.30
A3	2.49	2.59	2.69
b	0.76	-	0.89
b1	0.75	0.80	0.85
c	0.46	-	0.59
c1	0.45	0.50	0.55
C1	0.20	0.30	0.40
C2	1.00	1.10	1.20
D	10.10	10.20	10.30
E	9.05	9.15	9.25
e	4.98	5.08	5.18
e1	2.44	2.54	2.64
F1	1.22	-	1.60
F2	1.17	-	1.55
H	0.32	0.37	0.42
L	10.00	10.20	10.40
L1	3.15	3.30	3.45
L2	15.85	16.00	16.15
L3	29.30	29.60	29.90
L4	16.00	16.10	16.20
P	3.00	3.10	3.20
θ	3°	5°	7°
θ1	4°	6°	8°

Mechanical Dimensions
TO-220F (Package 2)

Unit: mm

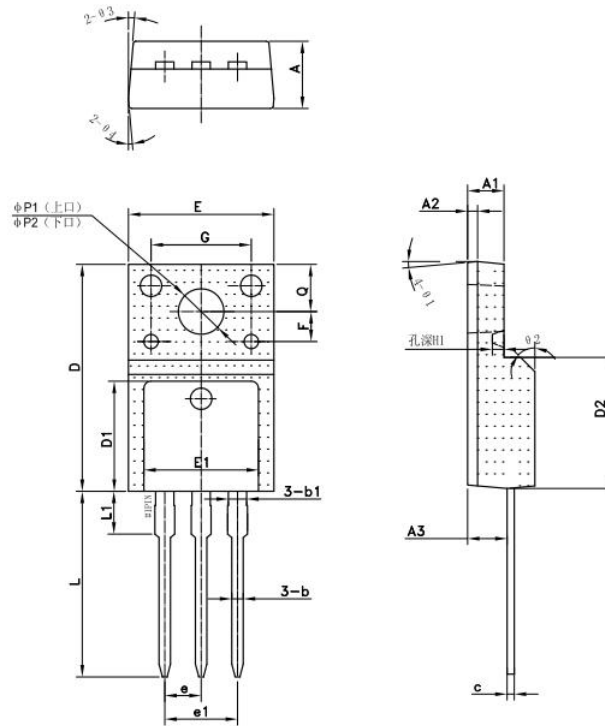

Symbol	Dimensions(mm)		
	Min.	Typ.	Max.
A	4.50	4.70	4.90
A1	2.34	2.54	2.70
A2	-	0.70	-
A3	2.56	2.76	2.96
b	0.70	0.80	0.95
b1	-	1.28	-
c	0.45	0.50	0.65
D	15.67	15.87	16.07
D1	-	7.70	-
D2	-	9.12	-
E	9.96	10.16	10.36
E1	-	8.00	-
e	2.54		
e1	5.08		
F	2.1		
G	7		
H1	-	0.81	-
L	12.48	12.98	13.20
L1	-	2.93	-
ΦP1 (上口)	2.98	3.18	3.38
ΦP2 (下口)	3.20	3.40	3.60
Q	3.10	3.30	3.50
θ1	5°		
θ2	45°		
θ2	5°		
θ3	5°		

Mechanical Dimensions
TO-220F (Package 3)

Unit: mm

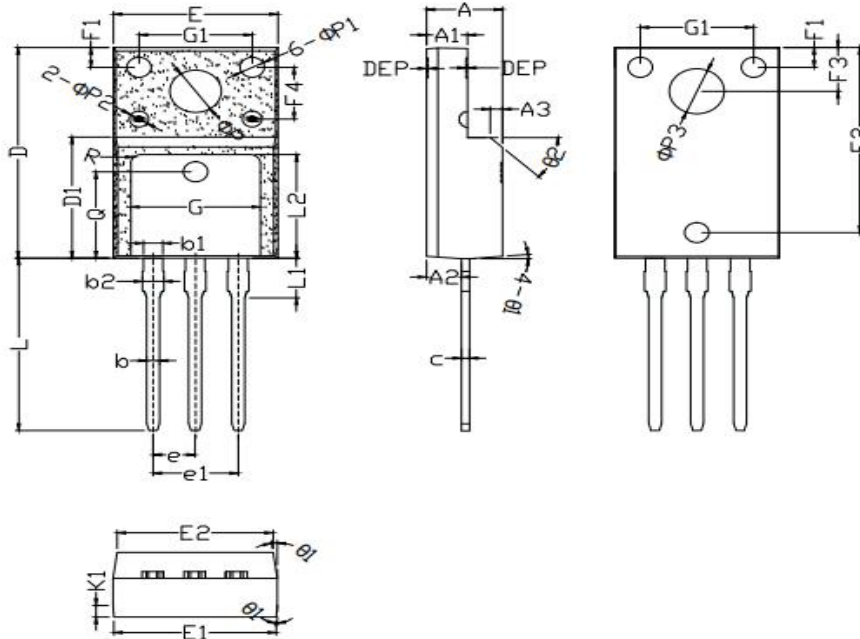

Symbol	Dimensions(mm)		
	Min.	Typ.	Max.
A	4.50	4.70	4.90
A1	2.34	2.54	2.74
A2	2.60	2.80	2.95
A3	1.0REF		
b	0.75	0.80	0.85
b1	1.18	1.20	1.24
b2	1.18	1.24	1.30
c	0.45	0.50	0.55
D	15.67	15.87	16.07
D1	9.04	9.12	9.20
E	10.00	10.16	10.30
E1	9.94	10.06	10.30
E2	9.40	9.50	9.60
e	2.50	2.54	2.58
e1	5.08REF		
L	12.78	12.98	13.18
L1	2.70	2.92	3.20
L2	7.70	7.80	7.90
Q	6.50REF		
ΦP	3.08	3.18	3.28
ΦP1	1.45	1.55	1.65
ΦP2	0.95	1.15	1.35
ΦP3	3.30	3.40	3.50
θ1	3°	5°	7°
θ2	42°	45°	48°
F1	1.40	1.50	1.60
F2	13.80	13.90	14.00
F3	3.20	3.30	3.40
F4	3.70	3.90	4.10
G	7.80	8.00	8.20
G1	6.90	7.00	7.10
K1	0.65	0.70	0.75

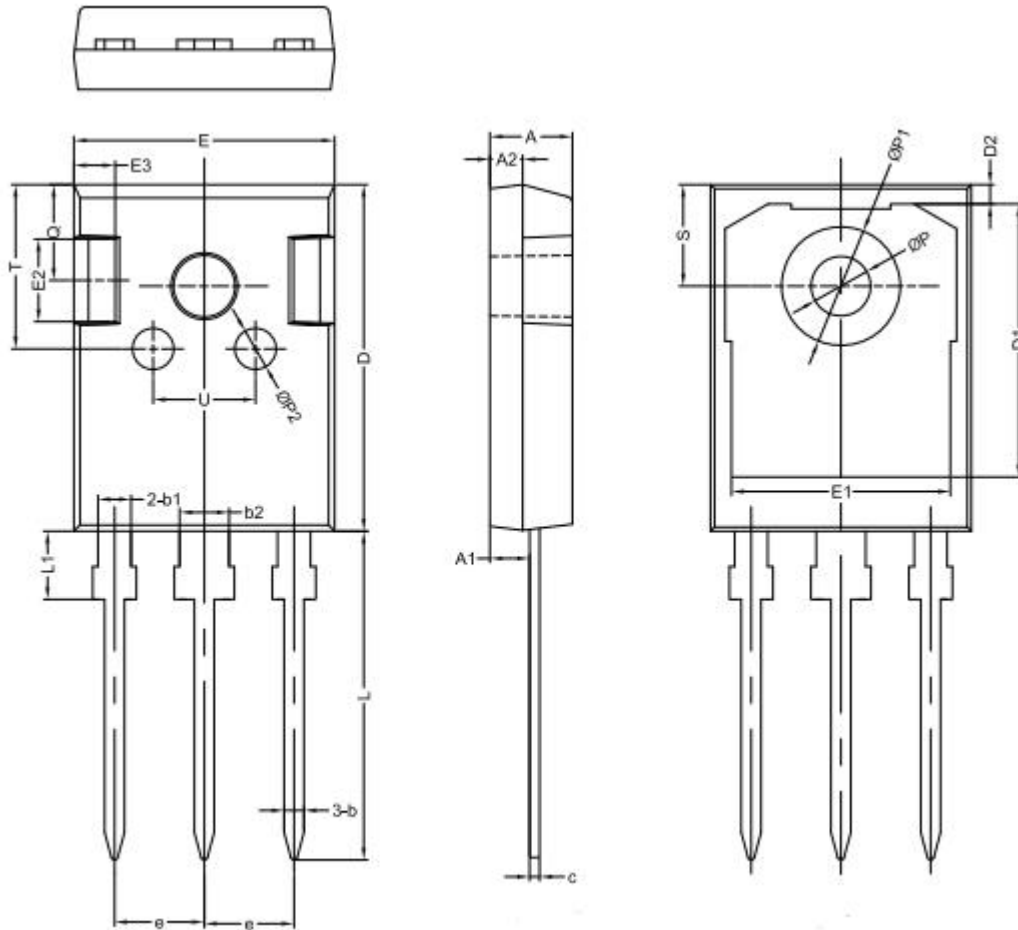
Mechanical Dimensions
TO-247(Package 1)
Unit: mm

Symbol	Dimensions(mm)			Symbol	Dimensions(mm)		
	Min.	Typ.	Max.		Min.	Typ.	Max.
A	4.80	5.00	5.20	E1	-	13.30	-
A1	2.21	2.41	2.61	E2	-	5.00	-
A2	1.90	2.00	2.10	E3	-	2.50	-
b	1.10	1.20	1.35	L	19.42	19.92	20.42
b1	-	2.00	-	L1	-	4.13	-
b2	-	3.00	-	P	3.50	3.60	3.70
c	0.55	0.60	0.75	P1	-	7.19	-
D	20.80	21.00	21.20	P2	-	2.50	-
D1	-	16.55	-	Q	-	5.80	-
D2	-	1.20	-	S	6.05	6.15	6.25
E	15.60	15.80	16.0	T	-	10.00	-
U	-	6.20	-				

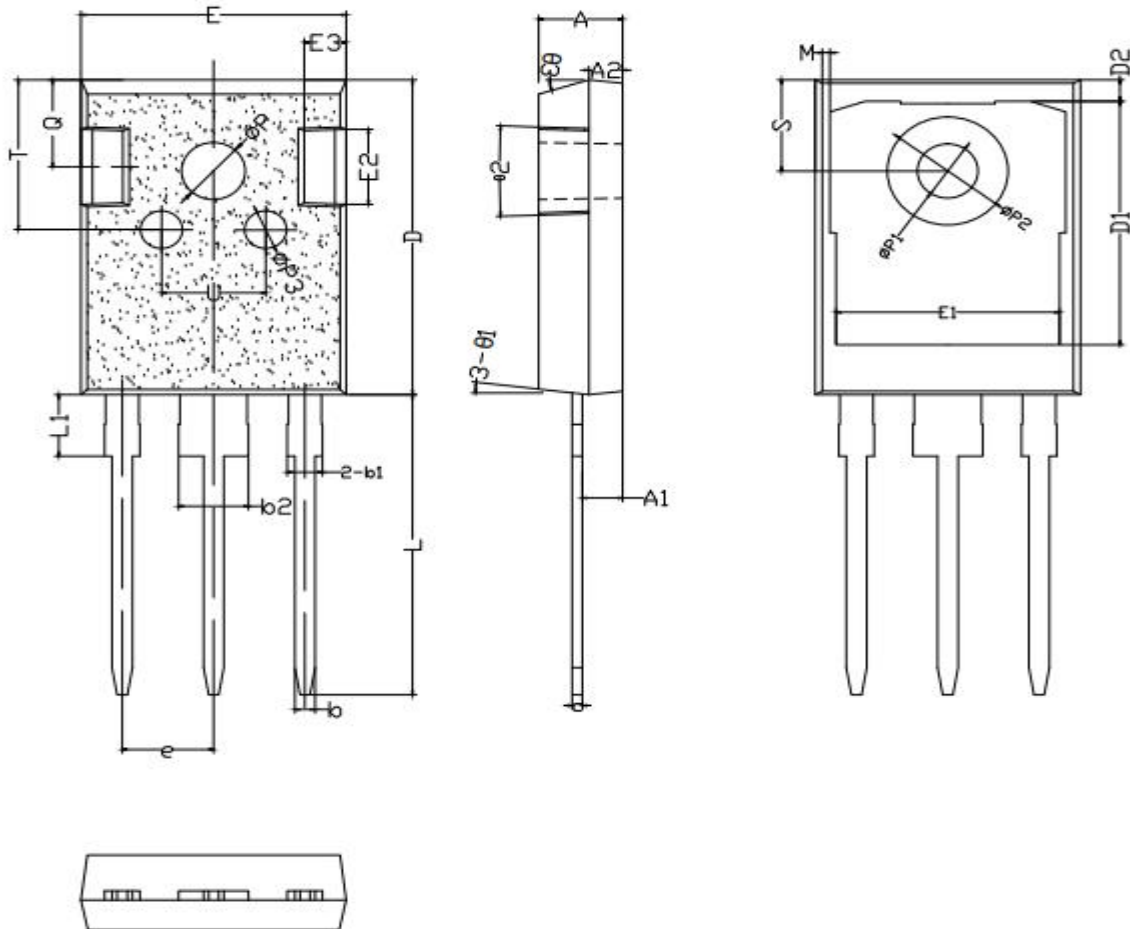
Mechanical Dimensions
TO-247(Package 2)
Unit: mm

Symbol	Dimensions(mm)			Symbol	Dimensions(mm)		
	Min.	Typ.	Max.		Min.	Typ.	Max.
A	4.90	5.00	5.10	E1	13.10	13.25	13.40
A1	2.31	2.41	2.51	E2	4.85	4.95	5.10
A2	1.90	2.00	2.10	E3	2.40	2.50	2.60
b	1.15	1.20	1.25	L	19.80	19.98	20.15
b1	1.95	2.10	2.25	L1	-	-	4.30
b2	2.95	3.10	3.25	ΦP	3.60	3.70	3.80
c	0.55	0.60	0.65	ΦP1	3.40	3.50	3.60
D	20.90	21.00	21.10	ΦP2	6.90	7.10	7.30
D1	16.35	16.55	16.75	Q	5.60	5.80	6.00
D2	1.05	1.20	1.35	S	6.05	6.15	6.25
E	15.70	15.80	15.90	T	9.80	10.00	10.20
U	6.00	6.20	6.40	e	5.40	5.44	5.48
θ1	5°	7°	9°	ΦP3	2.40	2.50	2.60
θ2	1°	3°	5°	θ3	13°	15°	17°

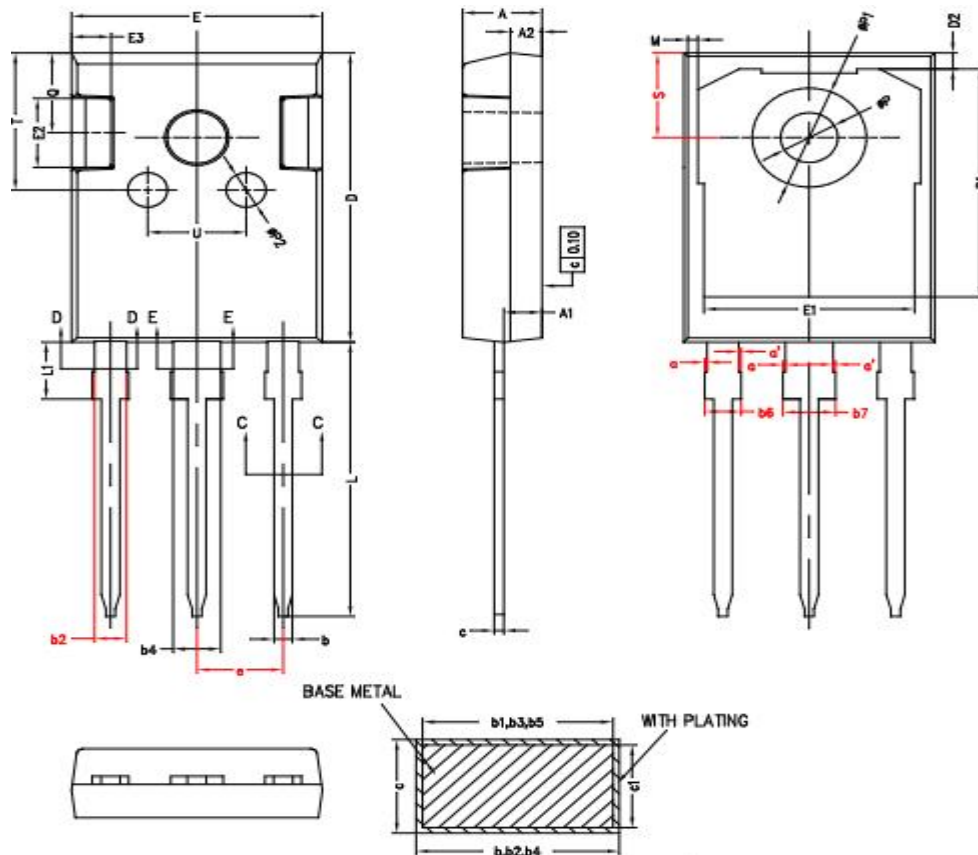
Mechanical Dimensions
TO-247(Package 4)
Unit: mm

Symbol	Dimensions(mm)			Symbol	Dimensions(mm)		
	Min.	Typ.	Max.		Min.	Typ.	Max.
A	4.90	5.00	5.10	E2	4.90	5.00	5.10
A1	2.31	2.41	2.51	E3	2.40	2.50	2.60
A2	1.90	2.00	2.10	e	5.34	5.44	5.54
b	1.12	-	1.22	L	19.80	19.92	20.10
b1	1.11	1.16	1.18	L1	3.95	4.13	4.30
b2	1.96	-	2.06	P	3.50	3.60	3.70
c	0.59	-	0.66	P1	7.00	-	7.40
D	20.90	21.00	21.10	P2	2.40	2.50	2.60
D1	16.25	16.55	16.85	Q	5.60	-	6.00
D2	1.05	1.20	1.35	S	6.05	6.15	6.25
E	15.70	15.80	15.90	T	9.80	-	10.20
E1	13.10	13.30	13.50	U	6.00	-	6.40
b3	1.95	2.00	2.02	b6	-	-	2.25
b4	2.96	-	3.06	b7	-	-	3.25
b5	2.95	3.00	3.02	c1	0.58	0.60	0.62
M	0.35	-	0.95	a	0	-	0.15
a'	0	-	0.15				

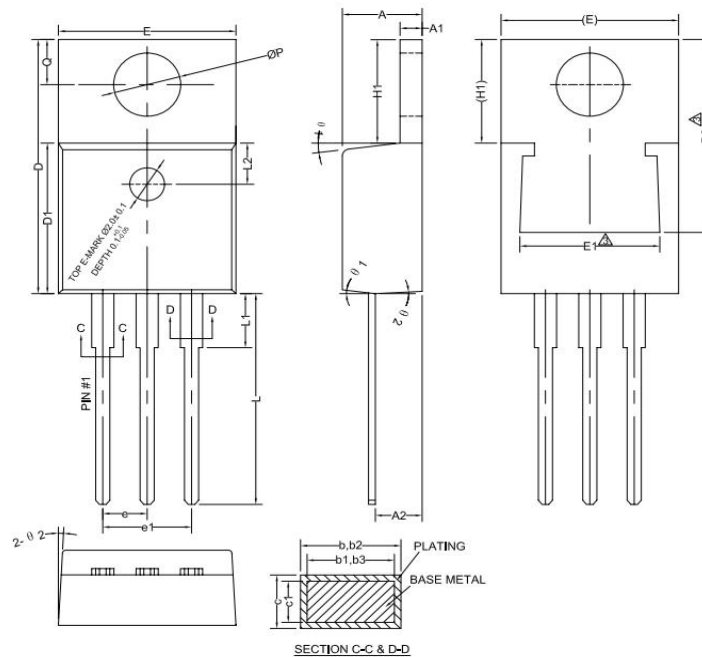
Mechanical Dimensions
TO-220C (Package 1)
Unit: mm

Symbol	Dimensions(mm)		
	Min.	Typ.	Max.
A	4.40	4.57	4.70
A1	1.22	-	1.32
A2	2.59	2.69	2.79
b	0.77	-	0.90
b1	0.76	0.81	0.86
b2	1.23	-	1.36
b3	1.22	1.27	1.32
c	0.34	-	0.47
c1	0.33	0.38	0.43
D	15.15	15.45	15.75
D1	9.05	9.15	9.25
D2	11.40	-	12.88
E	9.96	10.16	10.36
E1	6.86	-	8.89
e	2.44	2.54	2.64
e1	4.98	5.08	5.18
H1	6.10	6.30	6.50
L	12.70	-	13.12
L1	-	-	3.90
ΦP	3.80	3.84	3.88
Q	2.60	-	2.90
θ1	5°	7°	9°
θ2	1°	2°	5°

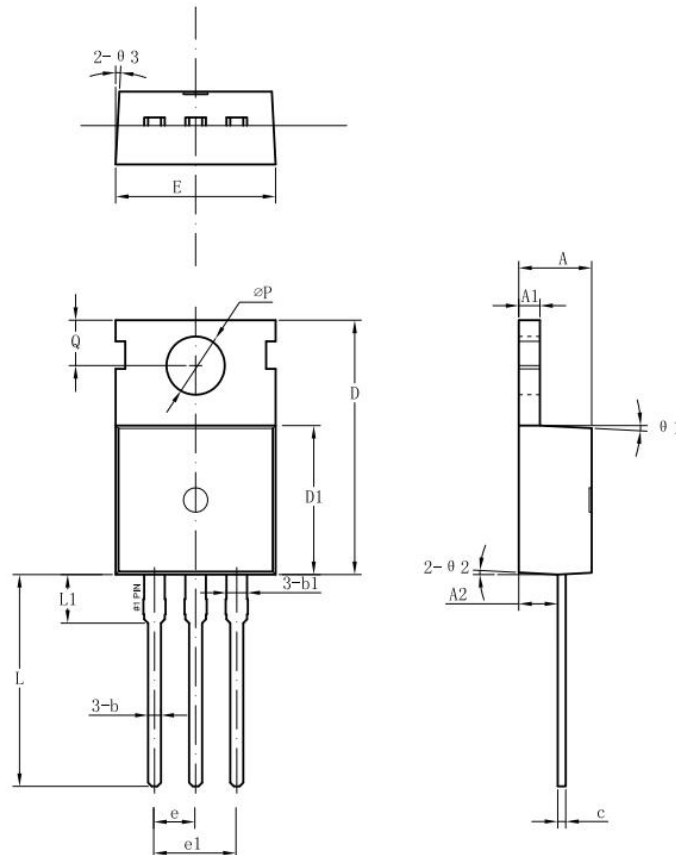
Mechanical Dimensions
TO-220C (Package 2)
Unit: mm

Symbol	Dimensions(mm)		
	Min.	Typ.	Max.
A	4.30	4.50	4.70
A1	1.25	1.30	1.40
A2	2.20	2.40	2.60
b	0.70	0.80	0.95
b1	-	1.27	-
c	0.40	0.50	0.65
D	15.20	15.70	16.20
D1	9.00	9.20	9.40
E	9.70	10.00	10.20
e		2.54	
e1		5.08	
L	12.60	13.08	13.60
L1	-	3.00	-
ΦP	3.50	3.60	3.80
Q	2.60	2.80	3.00
θ1		3°	
θ2		3°	
θ2		3°	

Mechanical Dimensions
TO-220C (Package 3)

Unit: mm

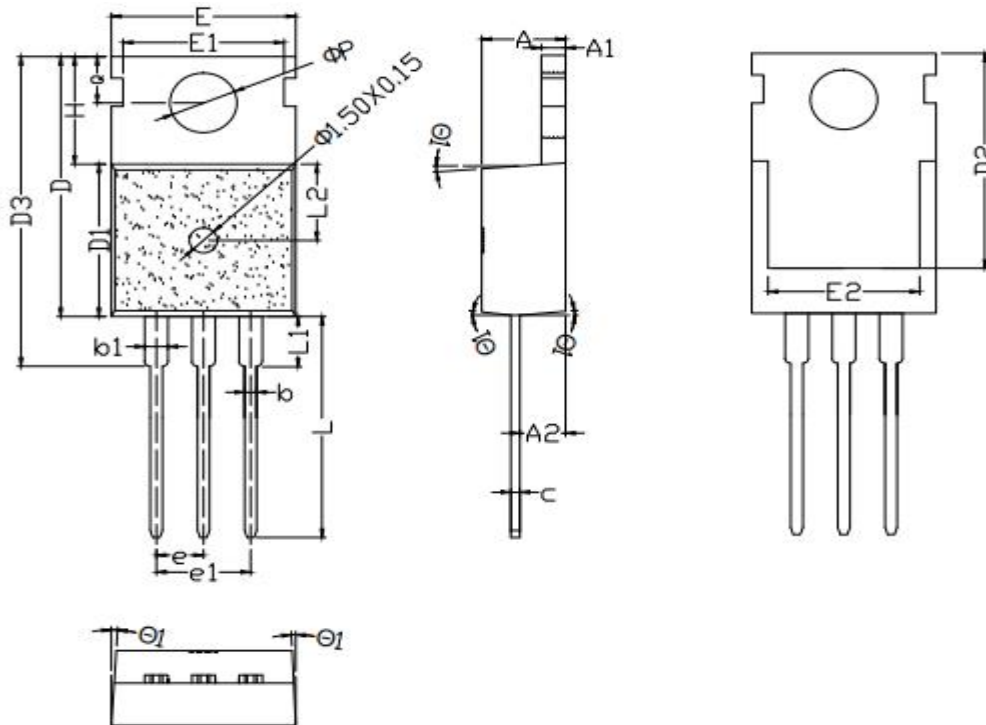

Symbol	Dimensions(mm)		
	Min.	Typ.	Max.
A	4.40	4.50	4.60
A1	1.25	1.30	1.35
A2	2.30	2.40	2.50
b	0.70	0.80	0.90
b1	1.25	1.33	1.42
c	0.45	0.50	0.55
D	15.50	15.75	16.00
D1	9.10	9.20	9.30
D2	12.90	13.10	13.30
D3	15.45	15.80	16.15
E	9.80	10.02	10.15
e	2.54BSC		
e1	5.08BSC		
L	13.00	13.28	13.45
L1	-	-	3.40
ΦP	3.55	3.65	3.75
Q	2.65	2.75	2.85
θ1	2°	-	7°
E1	8.55	8.70	8.85
E2	7.40	7.60	7.80
H	6.40	6.50	6.60
L2	4.50	4.65	4.80



Shenzhen Sanrise Technology Co., LTD.

<http://www.sanrise-tech.com>

IMPORTANT NOTICE

Shenzhen Sanrise Technology Co., LTD. reserves the right to make changes without further notice to any products or specifications herein. Shenzhen Sanrise Technology Co., LTD. does not assume any responsibility for use of any its products for any particular purpose, nor does Shenzhen Sanrise Technology Co., LTD. assume any liability arising out of the application or use of any its products or circuits. Shenzhen Sanrise Technology Co., LTD. does not convey any license under its patent rights or other rights nor the rights of others.

Main Site:

- Headquarter

Shenzhen Sanrise Technology Co., LTD.
A1206, Skyworth building, No. 008, gaoxinnan 1st Road,
Gaoxin District, Yuehai street,, Nanshan District, ShenZhen,
P.R.China
Tel: +86-755-22953335
Fax: +86-755-22916878

- Shanghai Office

Shenzhen Sanrise Technology Co., LTD.
Rm.401, Building B, No. 666, Zhangheng Road,
Zhangjiang Hi-Tech Park, Shanghai, P.R.China
Tel: +86-21-68825918