

General Description

The Sanrise SRT15N059H is a low voltage power MOSFET, fabricated using advanced split gate trench technology. The resulting device has extremely low on resistance, low gate charge and fast switching time, making it especially suitable for applications which require superior power density and synchronous rectification.

The SRT15N059H break down voltage is 150V and it has a high rugged avalanche characteristics. The SRT15N059H is available in TO-220C and TO-263-2 and TO-247 and TOLL packages.

Features

- Ultra Low
 $R_{DS(ON_TYP)} = 5.1m\Omega$, TO-220C @ $V_{GS} = 10V$.
 $R_{DS(ON_TYP)} = 5.0m\Omega$, TO-263-2@ $V_{GS} = 10V$
 $R_{DS(ON_TYP)} = 5.1m\Omega$, TO-247 @ $V_{GS} = 10V$
 $R_{DS(ON_TYP)} = 4.1m\Omega$, TOLL @ $V_{GS} = 10V$.
- Ultra Low Gate Charge, $Q_g=53.6nC$ typ.
- Fast switching capability
- Robust design with better EAS performance
- EMI Improved
- Non-automotive Qualified

Application

- Server/Telecom
- High Power Supply
- E-Tools
- BMS

Symbol

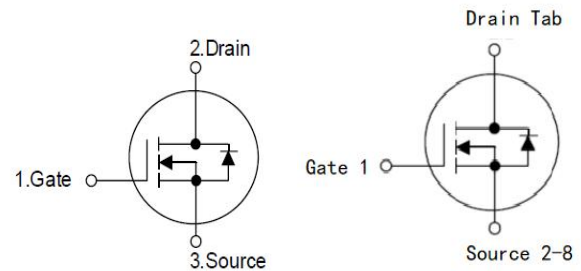

TO-263-2/TO-220C/TO-247

TOLL

Figure 1 Symbol of SRT15N059H

Package Type

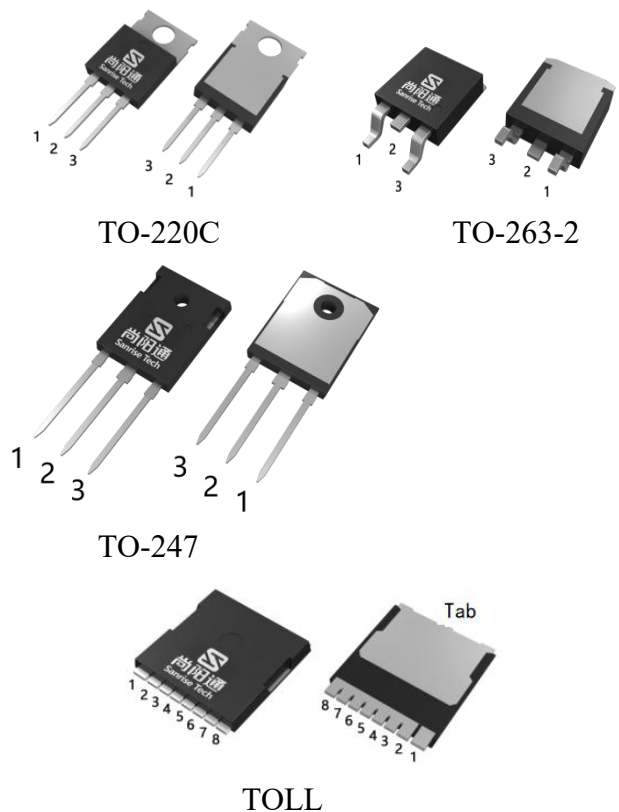
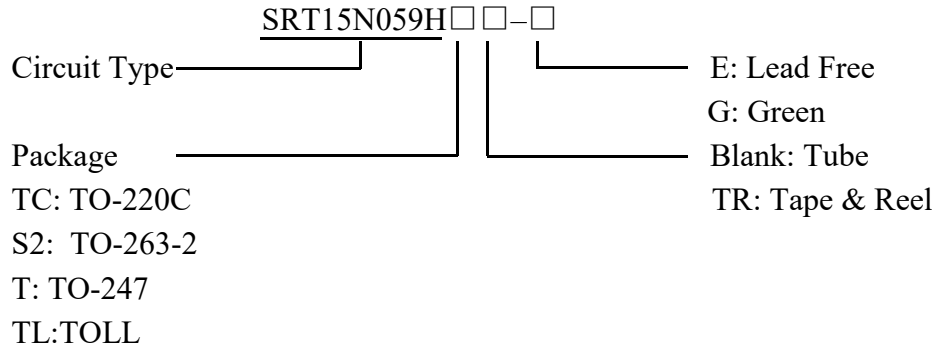

Figure 2 Package Type of SRT15N059H

Ordering Information

Package	Part Number		Marking ID		Packing Type
	Lead Free	Green	Lead Free	Green	
TO-220C	SRT15N059HTC-E	SRT15N059HTC-G	SRT15N059HTCE	SRT15N059HTCG	Tube
TO-263-2	SRT15N059HS2TR-E	SRT15N059HS2TR-G	SRT15N059HS2E	SRT15N059HS2G	Tape & Reel
TO-247	SRT15N059HT-E	SRT15N059HT-G	SRT15N059HTE	SRT15N059HTG	Tube
TOLL	SRT15N059HTLTR-E	SRT15N059HTLTR-G	SRT15N059HTLE	SRT15N059HTLG	Tape & Reel

Absolute Maximum Ratings

Parameter		Symbol	Rating		Unit
Drain-Source Voltage		V_{DSS}	150		V
Gate-Source Voltage		V_{GSS}	±20		V
Continuous Drain Current, Package limited	$T_C=25^{\circ}\text{C}$	I_D	TO-220C	120	A
			TO-263-2	120	
			TO-247	120	
			TOLL	180	
	$T_C=100^{\circ}\text{C}$		TO-220C	116	
			TO-263-2	116	
			TO-247	116	
			TOLL	160	
Continuous Drain Current, Silicon	$T_C=25^{\circ}\text{C}$	TO-220C	159		
		TO-263-2	159		
		TO-247	159		
		TOLL	180		
Pulsed Drain Current (Note 2)		I_{DM}	TO-220C	480	A
			TO-263-2	480	
			TO-247	480	
			TOLL	720	
Max Power Dissipation		P_D	265		W
Avalanche Destructive Energy, Single Pulse (Note 4)		E_{AS_Limit}	900		mJ
Avalanche Energy, Single Pulse (Note 3)		E_{AS}	183		mJ
Avalanche Energy, Repetitive (Note 2)		E_{AR}	0.4		mJ
Avalanche Current, Repetitive (Note 2)		I_{AR}	40.0		A
Continuous Diode Forward Current		I_S	120		A
Diode Pulse Current		$I_{S,PULSE}$	360		A
Operating Junction Temperature		T_J	175		$^{\circ}\text{C}$
Storage Temperature		T_{STG}	-55 to 175		$^{\circ}\text{C}$
Lead Temperature (Soldering, 10 sec)		T_{LEAD}	260		$^{\circ}\text{C}$

Note:

- Absolute maximum ratings are those values beyond which the device could be permanently damaged. Absolute maximum ratings are stress ratings only and functional device operation is not implied.
- Repetitive Rating: Pulse width limited by maximum junction temperature
- $I_{AS}=27\text{A}$, $V_{DD}=75\text{V}$, $R_G=25\Omega$, Starting $T_J=25^{\circ}\text{C}$
- $I_{AS_Limit}=60\text{A}$, $V_{DD}=75\text{V}$, $R_G=25\Omega$, Starting $T_J=25^{\circ}\text{C}$

Thermal Resistance

Parameter		Symbol	Min	Typ	Max	Unit
Thermal Resistance, Junction-to-Case	TO-220C	R_{thJC}			0.47	°C/W
	TO-263-2				0.47	
	TO-247				0.47	
	TOLL				0.40	
Thermal Resistance, Junction-to-Ambient		R_{thJA}			62	

5.9mΩ, 150V, N-Channel Power MOSFET
SRT15N059H
Electrical Characteristics
 $T_J = 25^\circ\text{C}$, unless otherwise specified.

Parameter	Symbol	Test Conditions	Min	Typ	Max	Unit
Statistic Characteristics						
Drain-Source Breakdown Voltage	BV_{DSS}	$V_{GS}=0V, I_D=250\mu A$	150			V
Zero Gate Voltage Drain Current	I_{DSS}	$V_{DS}=150V, V_{GS}=0V$			1	μA
Gate-Body Leakage Current	Forward	$I_{GSSF}, V_{GS}=20V, V_{DS}=0V$			100	nA
	Reverse	$I_{GSSR}, V_{GS}=-20V, V_{DS}=0V$			-100	
Gate Threshold Voltage	$V_{GS(TH)}$	$V_{DS}=V_{GS}, I_D=0.25mA$	2.0	3.0	4.0	V
Static Drain-Source On-Resistance	TO-220C	$R_{DS(ON)}, V_{GS}=10V, I_D=60A$		5.1	5.9	$m\Omega$
	TO-263-2			5.0	5.8	$m\Omega$
	TO-247			5.1	5.9	$m\Omega$
	TOLL			4.1	5.0	$m\Omega$
Gate Resistance	R_G	$f=1MHz, \text{Open Drain}$		1.3		Ω
Dynamic Characteristics						
Input Capacitance	C_{ISS}	$V_{DS}=50V, V_{GS}=0V, f=1MHz$		3.6		nF
Output Capacitance	C_{OSS}			2.4		nF
Reverse Transfer Capacitance	C_{RSS}			39		pF
Effective output capacitance, energy related ^{NOTE5}	$C_{O(er)}$	$V_{GS}=0V, V_{DS}=0\dots 90V$		2.3		nF
Effective output capacitance, time related ^{NOTE6}	$C_{O(tr)}$			2.8		
Turn-on Delay Time	$t_{d(on)}$	$V_{DD}=75V, I_D=60A, R_G=1.6\Omega, V_{GS}=10V$		12		ns
Rise Time	t_r			5		
Turn-off Delay Time	$t_{d(off)}$			14		
Fall Time	t_f			4		
Gate Charge Characteristics						
Gate to Source Charge	Q_{gs}	$V_{DD}=75V, I_D=60A, V_{GS}=0 \text{ to } 10V$		18.0		nC
Gate to Drain Charge	Q_{gd}			12.4		
Gate Charge Total	Q_g			53.6		
Gate Plateau Voltage	$V_{plateau}$			5.0		V
Gate Charge Total, sync FET	Q_g	$V_{DD}=0.1V, V_{GS}=0 \text{ to } 10V$		44.8		nC
Reverse Diode Characteristics						
Drain-Source Diode Forward Voltage	V_{SD}	$V_{GS}=0V, I_{SD}=60A$		0.87	1.1	V
Reverse Recovery Time	t_{rr}	$V_R=75V, I_F=60A, dI_F/dt=100A/\mu s$		52		ns
Reverse Recovery Charge	Q_{rr}			86		nC
Peak Reverse Recovery Current	I_{rrm}			3.3		A

Note:

- $C_{O(er)}$ is a fixed capacitance that gives the same stored energy as C_{OSS} while V_{DS} is rising from 0 to 60V
- $C_{O(tr)}$ is a fixed capacitance that gives the same charging time as C_{OSS} while V_{DS} is rising from 0 to 60V

Typical Performance Characteristics

Figure 3: Power Dissipation

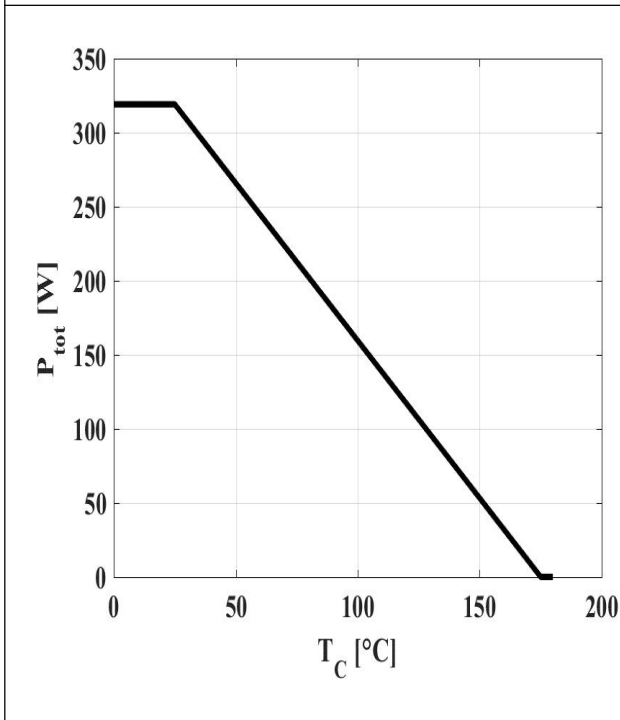

$$P_{tot}=f(T_c)$$

Figure 4: Max. Transient Thermal Impedance

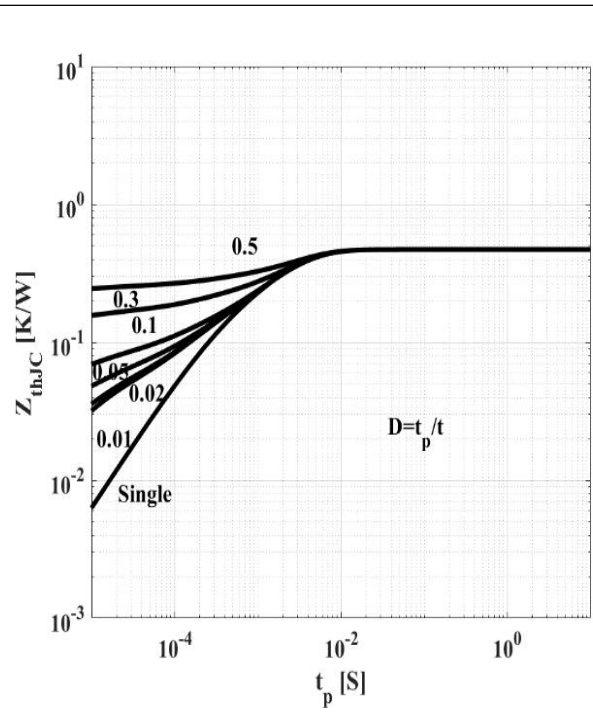

$$Z_{(th)JC}=f(t_p); \text{parameter: } D=t_p/t$$

Figure 5: Drain Current

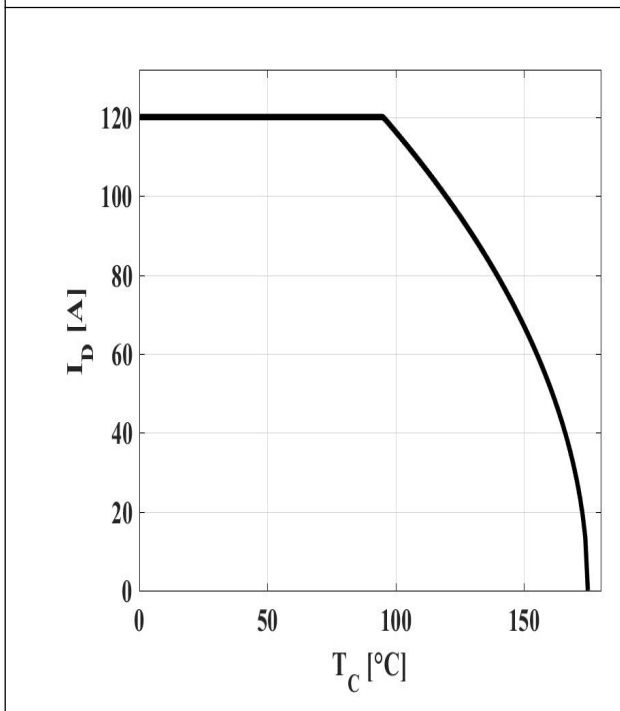

$$I_D=f(T_c); V_{GS} \geq 10V$$

Figure 6: Typ. Output Characteristics

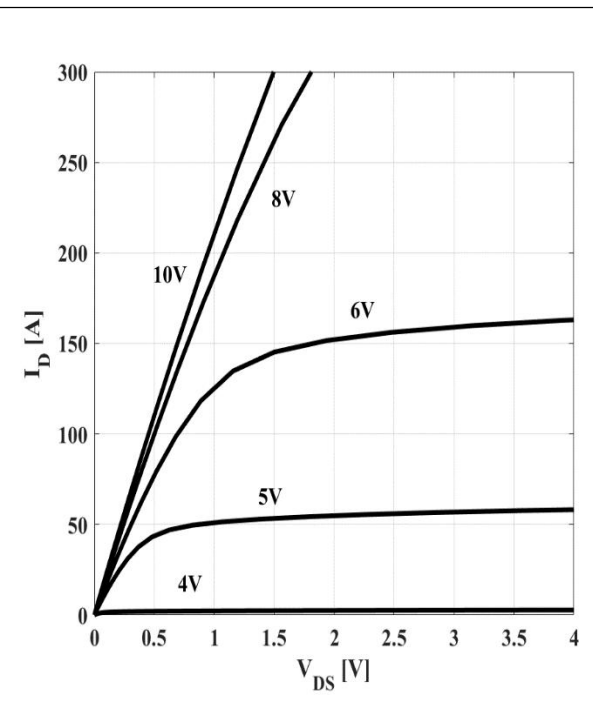

$$I_D=f(V_{DS}); T_j=25^\circ C; \text{parameter: } V_{GS}$$

Figure7: Typ. Drain-Source On-State Resistance

 $R_{DS(ON)}=f(I_D); T_j=25^{\circ}C$; parameter: V_{GS}
Figure8: Typ. Transfer Characteristics

 $I_D=f(V_{GS}); |V_{DS}|>2|I_D|R_{DS(on)max}$; parameter: T_j
Figure9: Typ. Forward Transconductance

 $g_{fs}=f(I_D); T_j=25^{\circ}C$
Figure10: Typ. Drain-Source On-State Resistance

 $R_{DS(ON)}=f(T_j); I_D=60A; V_{GS}=10V$

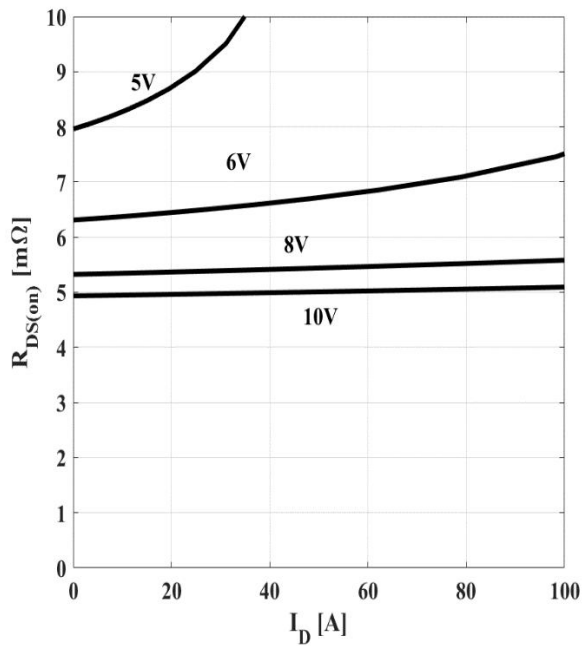
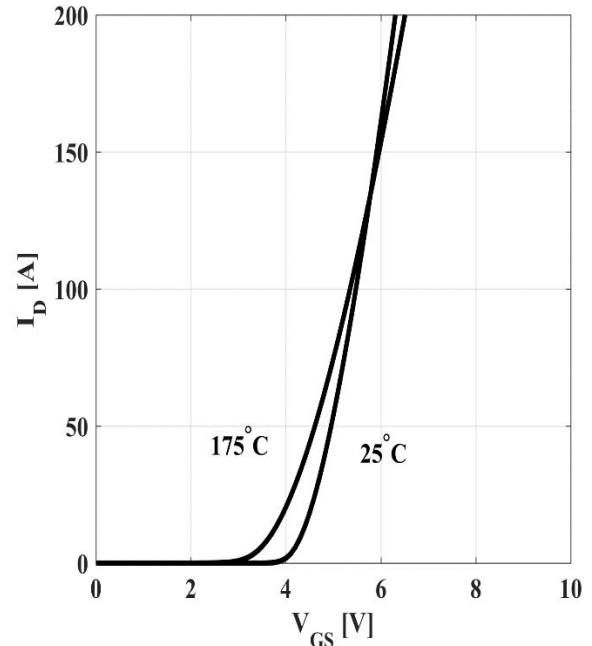
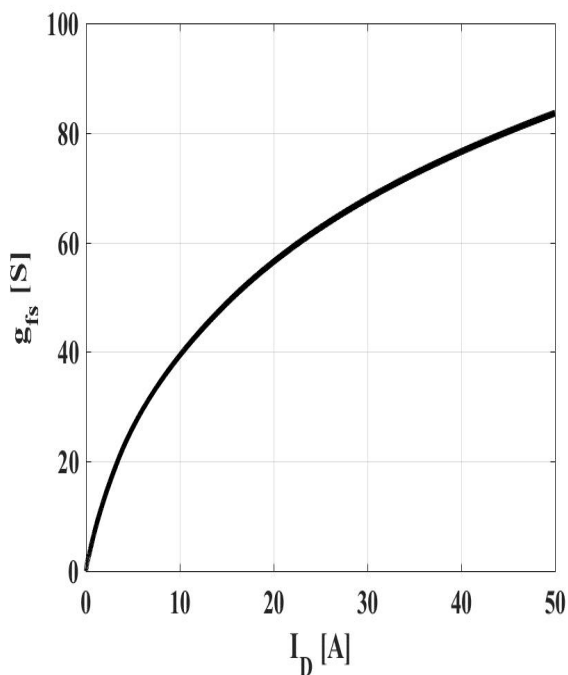
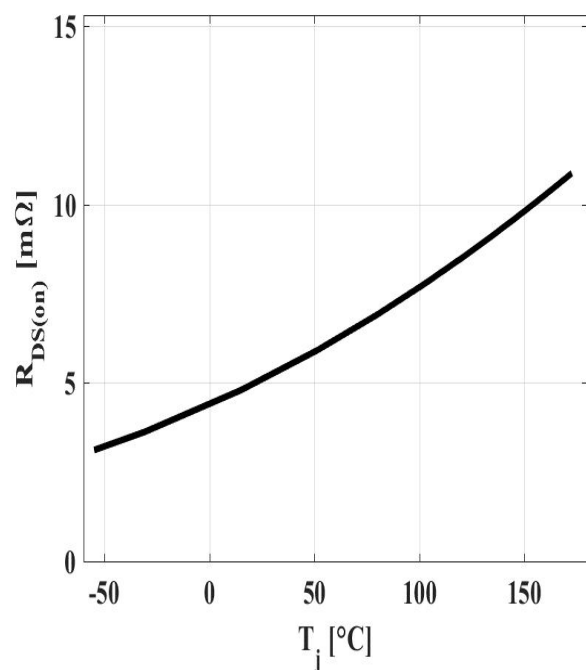
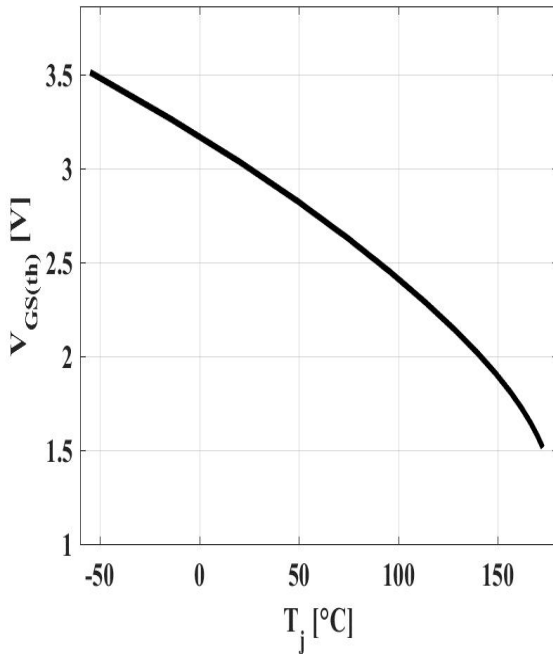
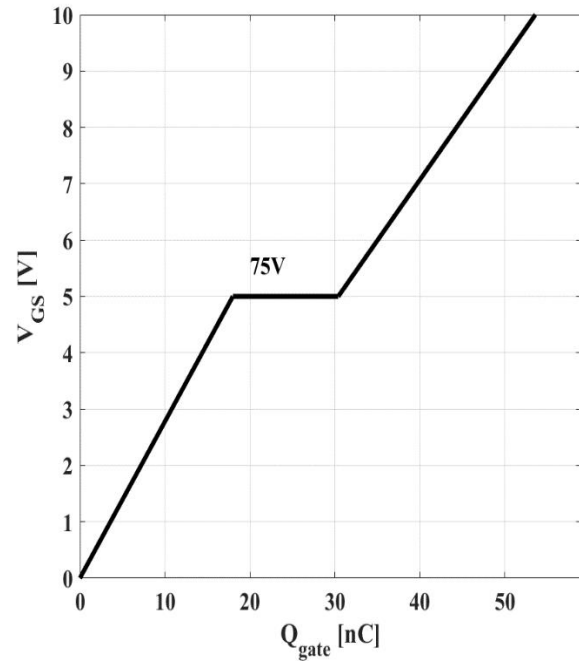
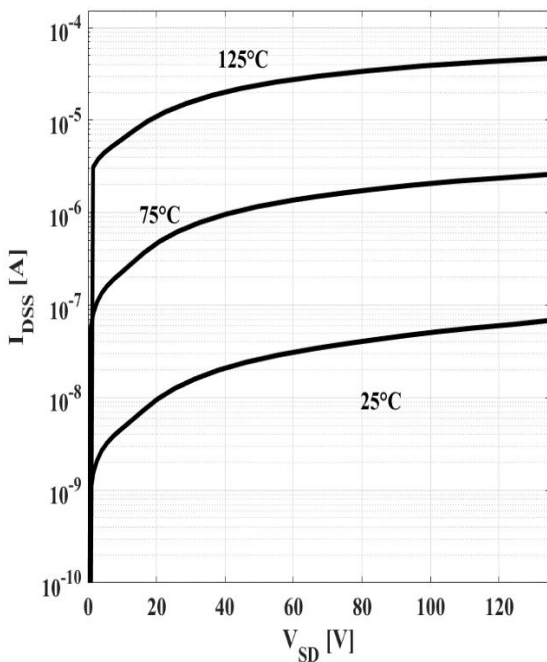
Figure 11: Typ. Gate Threshold Voltage

$$V_{GS(th)} = f(T_j); V_{GS} = V_{DS}; I_{DS} = 250\mu A$$

Figure 12: Typ. Gate Charge

$$V_{GS} = f(Q_{gate}), I_D = 60A \text{ pulsed}$$

Figure 13: Drain-Source Leakage Current

$$I_{DSS} = f(V_{DS}); V_{GS} = 0V; \text{parameter: } T_j$$

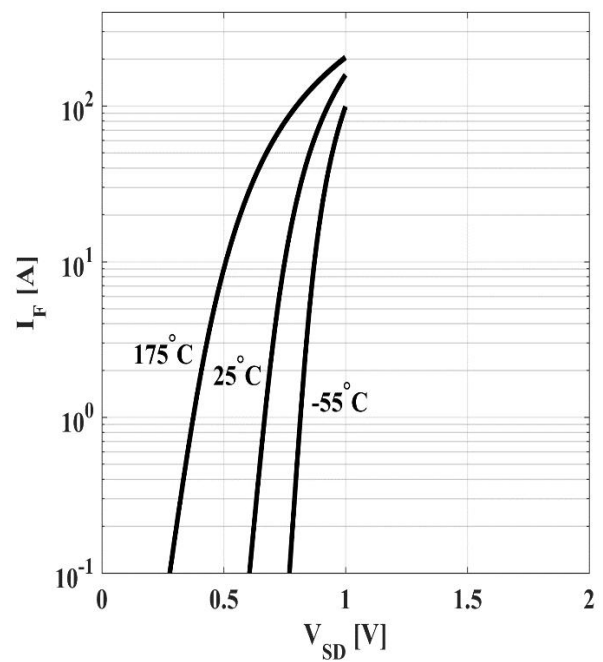
Figure 14: Forward Characteristics of Reverse Diode

$$I_F = f(V_{SD}); \text{parameter: } T_j$$

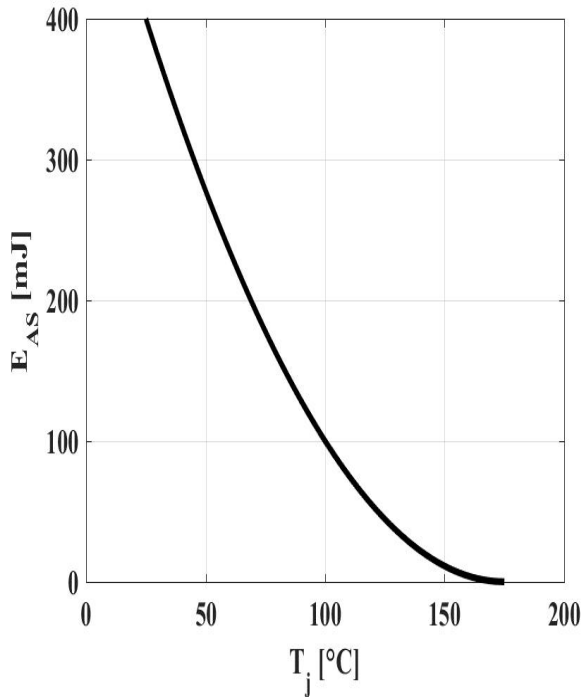
Figure 15: Avalanche Energy

$$E_{AS}=f(T_j); I_D=40.0A; V_{DD}=75V$$

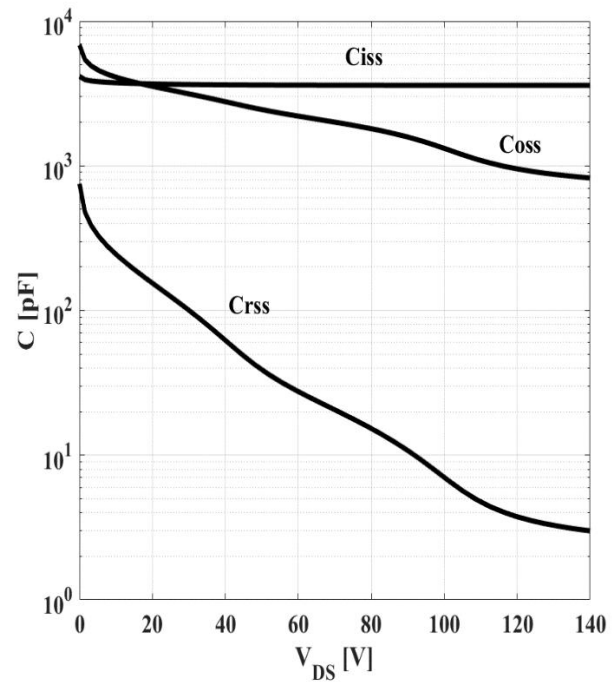
Figure 16: Typ. Capacitances

$$C=f(V_{DS}); V_{GS}=0; f=1MHz$$

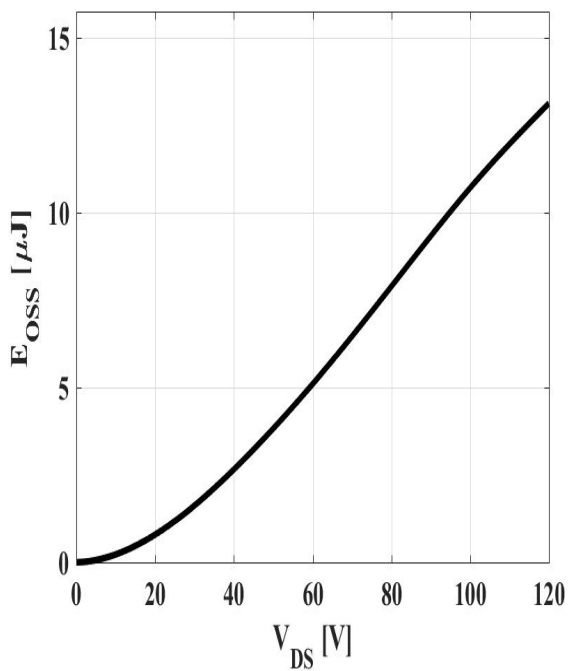
Figure 17: C_{oss} Stored Energy

$$E_{OSS}=f(V_{DS})$$

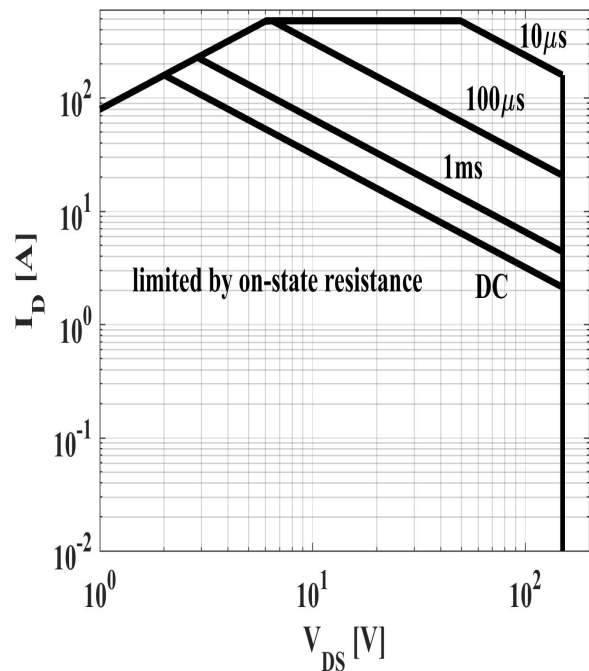
Figure 18: Safe Operating Area

$$I_D = f(V_{DS}); T_c = 25^\circ C; V_{GS} > 7V; \text{parameter } t_p$$

Test Circuits

1. Gate Charge Test Circuit & Waveform

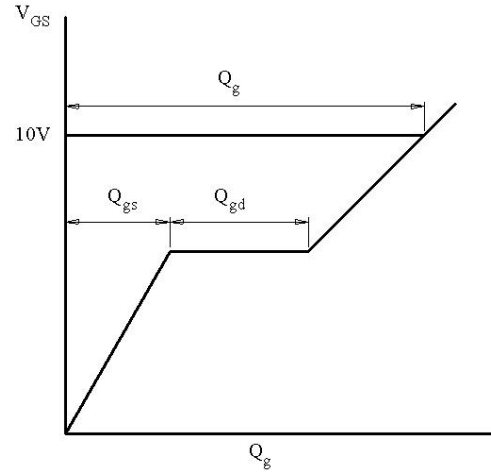
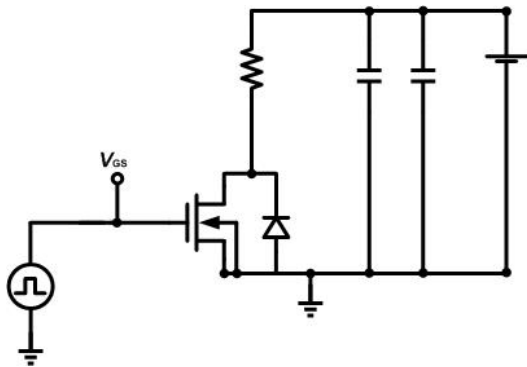

2. Switch Time Test Circuit

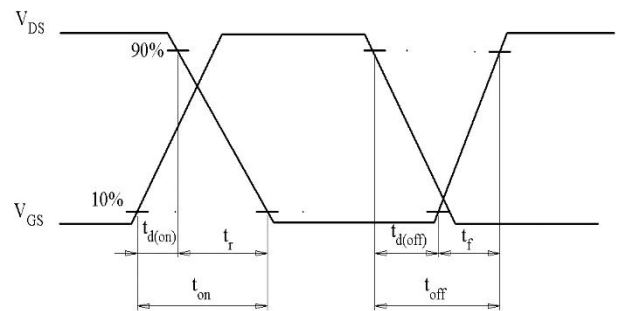
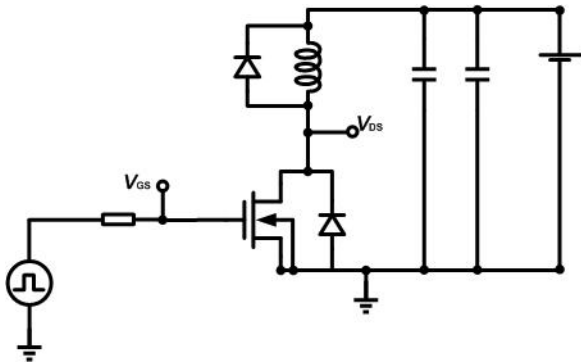

3. Unclamped Inductive Switching Test Circuit & Waveforms

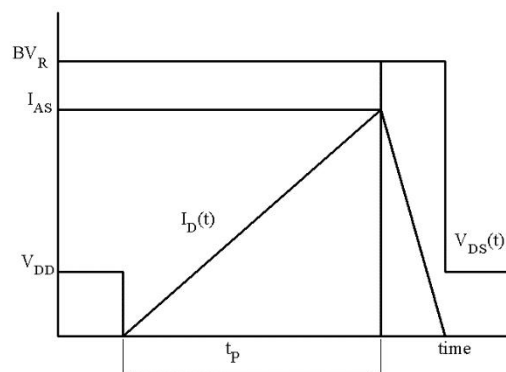
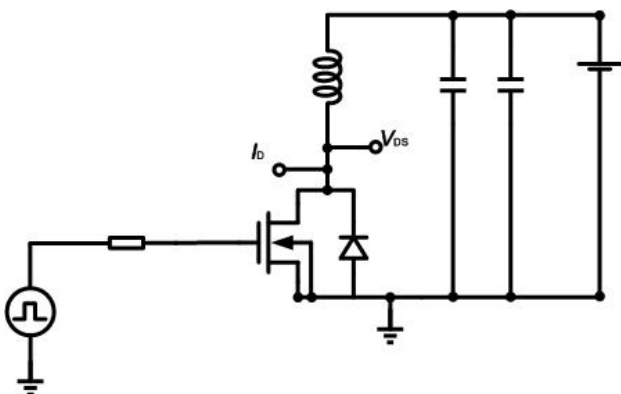

4. Test Circuit and Waveform for Diode Characteristics

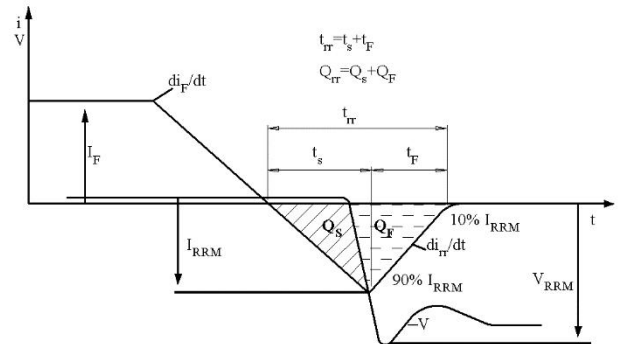
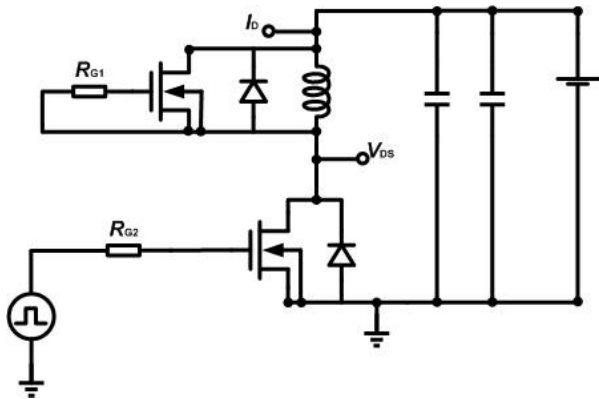

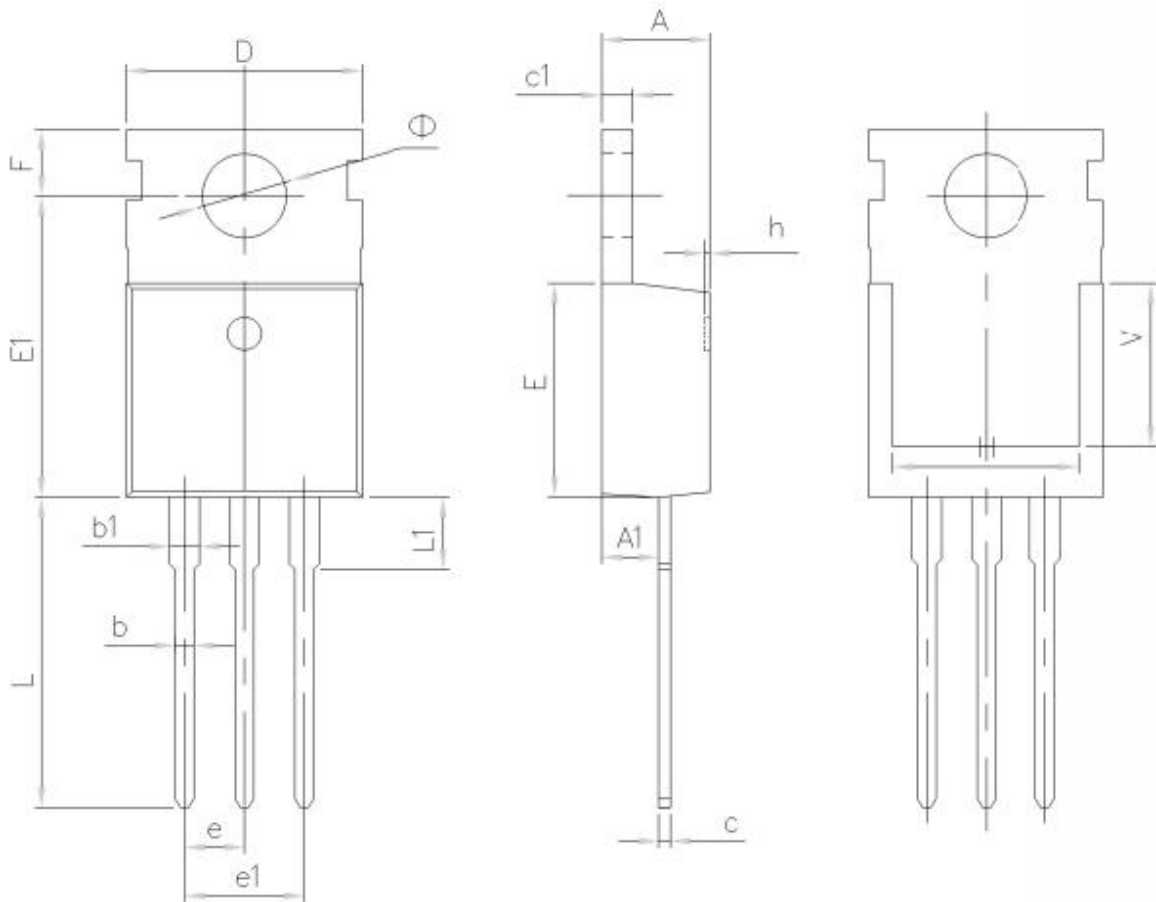
Mechanical Dimensions
TO-220C(Package1)
Unit: mm

Symbol	Dimensions (mm)			Symbol	Dimensions (mm)		
	Min.	Typ.	Max.		Min.	Typ.	Max.
A	4.40	4.50	4.60	e	-	2.54	-
A1	2.25	2.40	2.55	e1	4.98	5.08	5.18
b	0.71	0.81	0.91	F	2.65	2.80	2.95
b1	1.17	1.27	1.37	H	7.90	8.00	8.10
c	0.33	0.50	0.65	h	0.00	-	0.30
c1	1.20	1.30	1.40	L	12.90	13.15	13.40
D	9.91	-	10.25	L1	2.85	3.05	3.25
E	8.95	-	9.75	V	-	6.90REF	-
E1	12.65	12.85	13.05	Φ	3.40	3.60	3.80

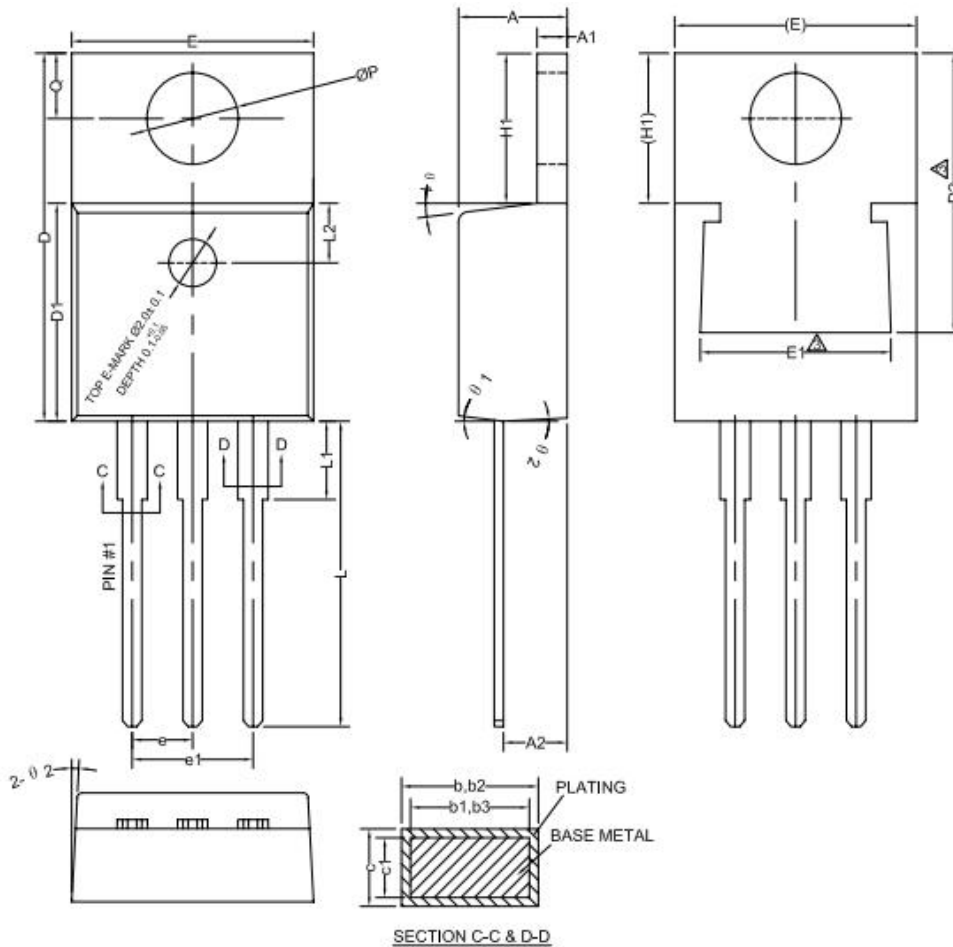
Mechanical Dimensions
TO-220C(Package2)
Unit: mm

Symbol	Dimensions (mm)			Symbol	Dimensions (mm)		
	Min.	Typ.	Max.		Min.	Typ.	Max.
A	4.40	4.57	4.70	E	9.96	10.16	10.36
A1	1.22	-	1.32	E1	6.86	-	8.89
A2	2.59	2.69	2.79	e	2.44	2.54	2.64
b	0.77	-	0.90	e1	4.98	5.08	5.18
b1	0.76	0.81	0.86	H1	6.10	6.30	6.50
b2	1.23	-	1.36	L	12.70	-	13.12
b3	1.22	1.27	1.32	L1	-	-	3.90
c	0.34	-	0.47	L2	-	2.50REF	-
c1	0.33	0.38	0.43	ΦP	3.80	3.84	3.88
D	15.15	15.45	15.75	Q	2.60	-	2.90
D1	9.05	9.15	9.25	θ 1	5°	7°	9°
D2	11.40	-	12.88	θ 2	1°	3°	5°

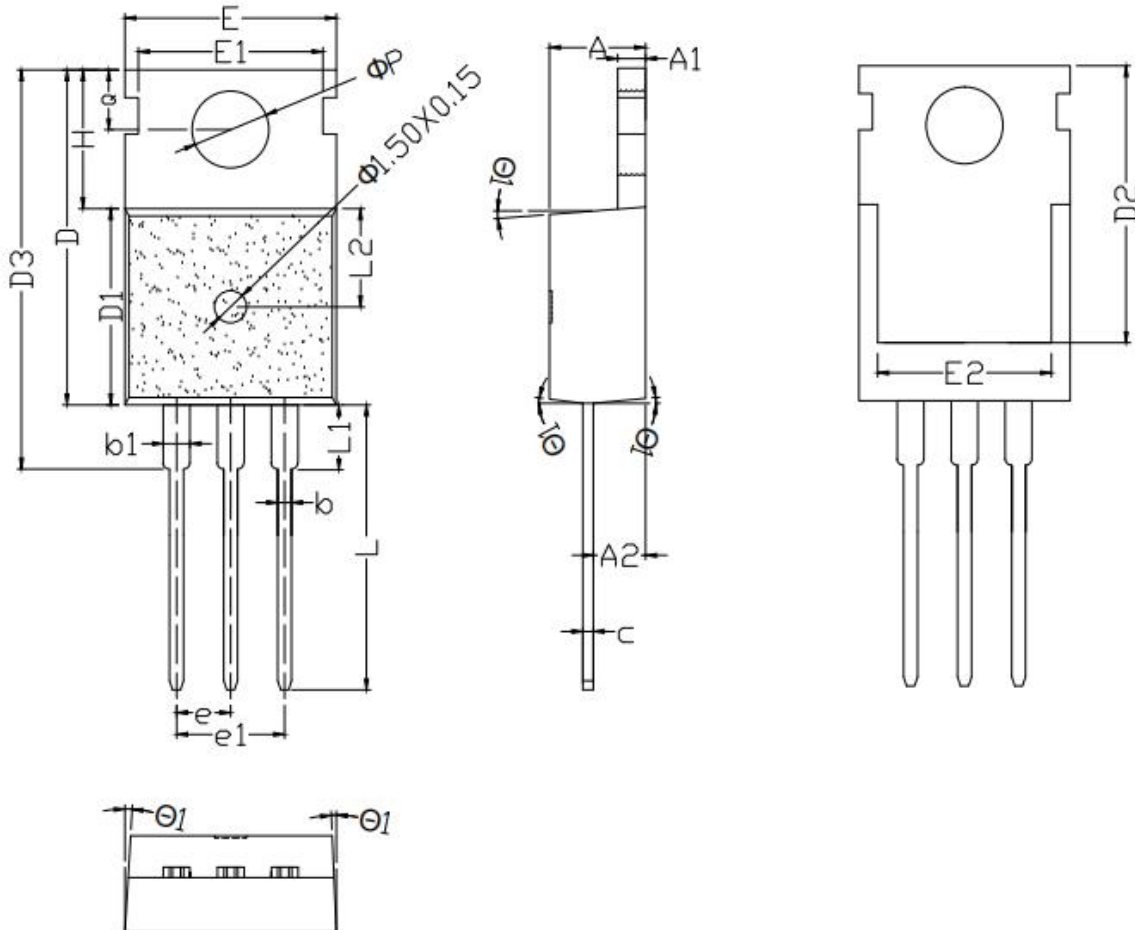
Mechanical Dimensions
TO-220C(Package3)
Unit: mm

Symbol	Dimensions (mm)			Symbol	Dimensions (mm)		
	Min.	Typ.	Max.		Min.	Typ.	Max.
A	4.40	4.50	4.60	E2	7.40	7.60	7.80
A1	1.25	1.30	1.35	e	-	2.54BSC	-
A2	2.30	2.40	2.50	e1	-	5.08BSC	-
b	0.70	0.80	0.90	H	6.40	6.50	6.60
b1	1.25	1.33	1.42	L	13.00	13.28	13.45
c	0.45	0.50	0.55	L1	-	-	3.40
D	15.50	15.75	16.00	L2	4.50	4.65	4.80
D1	9.10	9.20	9.30	L3	1.10	1.30	1.50
D2	12.90	13.10	13.30	ΦP	3.55	3.65	3.75
D3	15.45	15.80	16.15	Q	2.65	2.75	2.85
E	9.80	10.02	10.15	θ 1	2°	-	7°
E1	8.55	8.70	8.85				

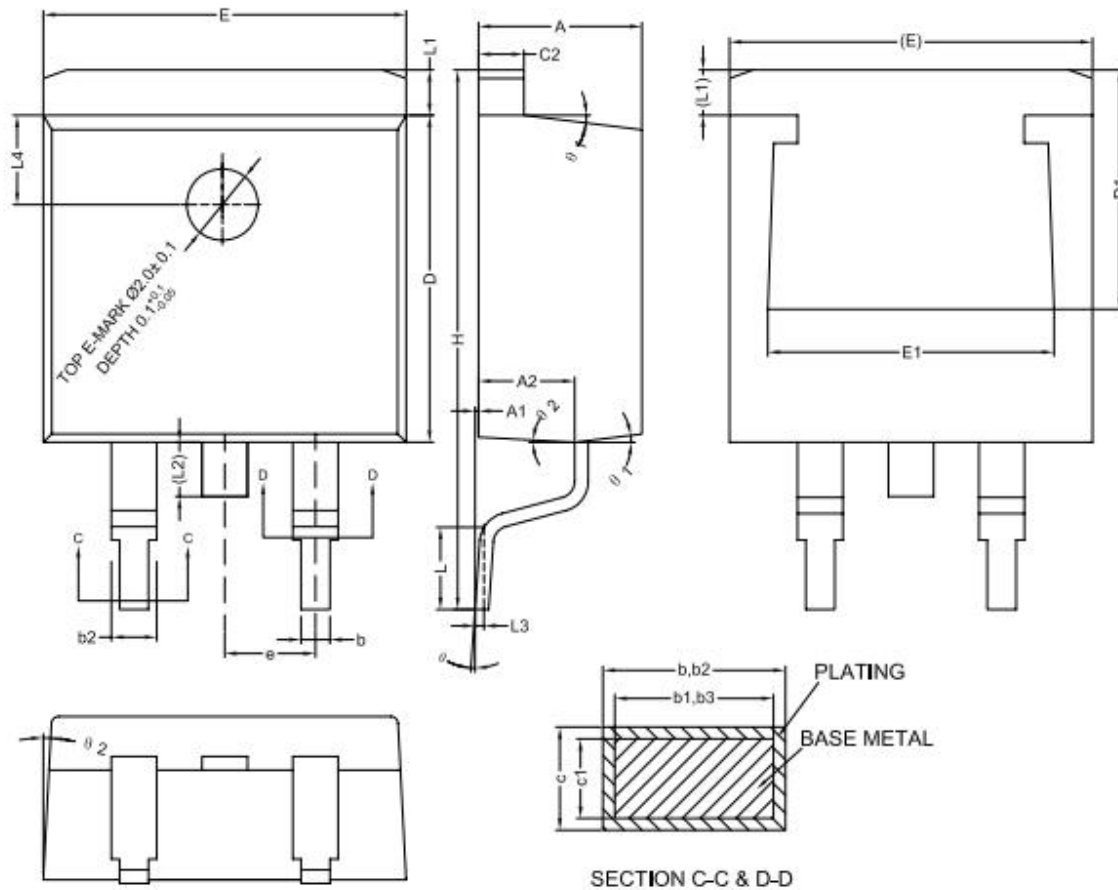
Mechanical Dimensions
TO-263-2(Package1)
Unit: mm

Symbol	Dimensions (mm)			Symbol	Dimensions (mm)		
	Min.	Typ.	Max.		Min.	Typ.	Max.
A	4.40	4.57	4.70	E	10.06	10.16	10.26
A1	0.00	0.10	0.25	E1	7.80	–	8.20
A2	2.59	2.69	2.79	e	–	2.54BSC	–
b	0.77	–	0.90	H	14.70	15.10	15.50
b1	0.76	0.81	0.86	L	2.00	2.30	2.60
b2	1.23	–	1.36	L1	1.17	1.27	1.40
b3	1.22	1.27	1.32	L2	–	–	1.75
c	0.34	–	0.47	L3	–	0.25BSC	–
c1	0.33	0.38	0.43	L4	–	2.00REF	–
c2	1.22	–	1.32	⊙	0°	–	8°
D	9.05	9.15	9.25	⊙1	5°	7°	9°
D1	6.60	–	–	⊙2	1°	3°	5°

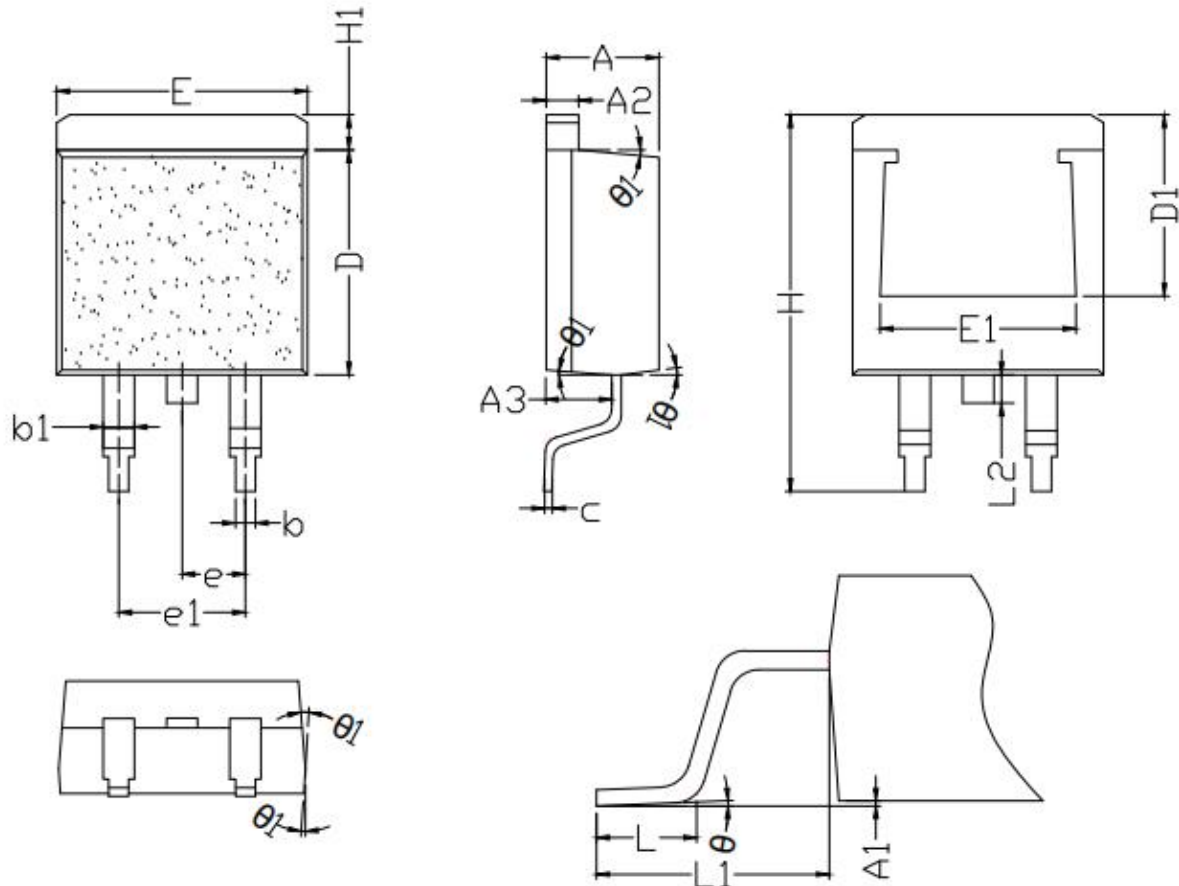
Mechanical Dimensions
TO-263-2(Package2)
Unit: mm

Symbol	Dimensions (mm)			Symbol	Dimensions (mm)		
	Min.	Typ.	Max.		Min.	Typ.	Max.
A	4.42	4.52	4.62	E1	-	7.85REF	-
A1	0.00	0.10	0.20	e	2.50	2.54	2.58
A2	1.24	1.27	1.32	e1	-	5.08REF	-
A3	2.50	2.60	2.70	H	14.80	15.10	15.30
b	0.77	0.81	0.84	H1	1.12	1.28	1.42
b1	1.23	1.28	1.41	L	2.10	2.23	2.36
c	0.33	0.38	0.43	L1	4.55	4.75	4.95
D	8.80	8.95	9.10	L2	1.10	1.30	1.50
D1	-	7.25REF	-	∅	0°	2°	5°
E	9.92	10.07	10.22	∅1	3°	-	9°

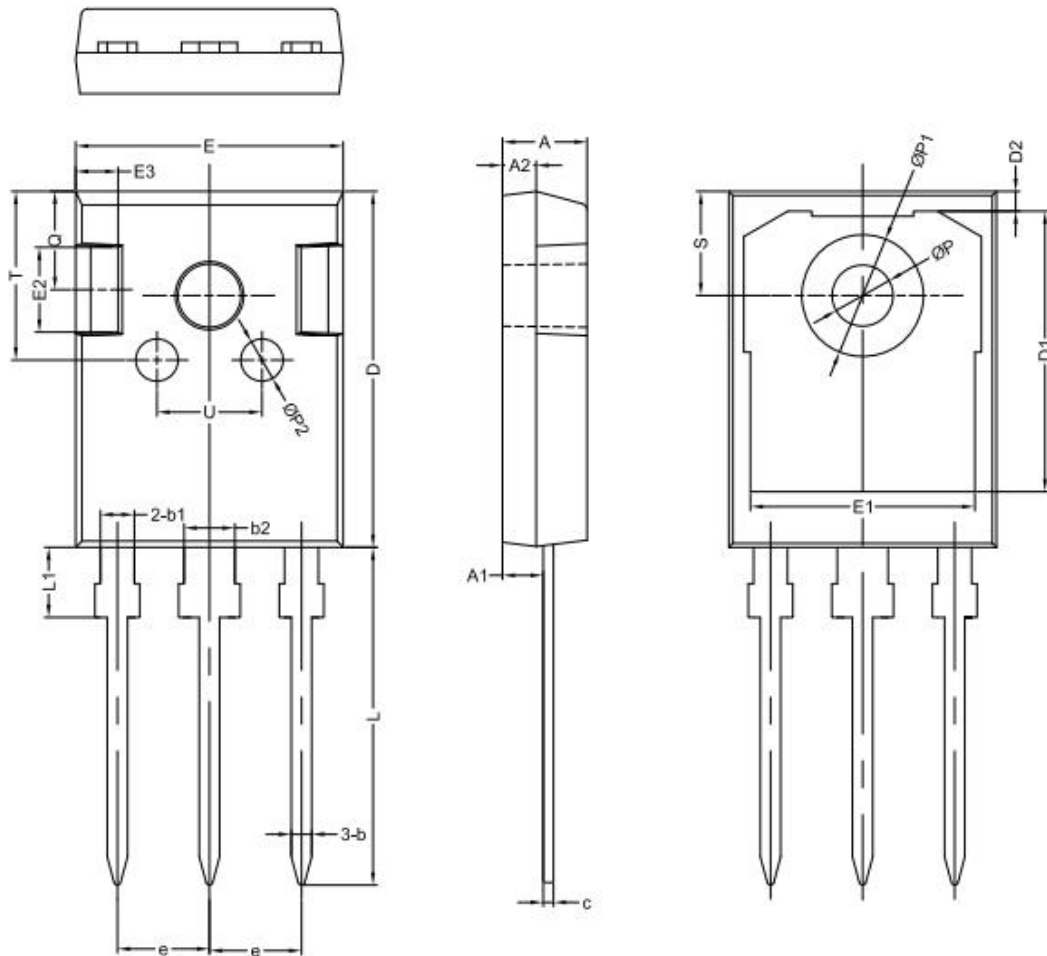
Mechanical Dimensions
TO-247 (Package1)
Unit: mm

Symbol	Dimensions (mm)			Symbol	Dimensions (mm)		
	Min.	Typ.	Max.		Min.	Typ.	Max.
A	4.80	5.00	5.20	E2	-	5.00	-
A1	2.21	2.41	2.61	E3	-	2.50	-
A2	1.90	2.00	2.10	e	-	5.44	-
b	1.10	1.20	1.35	L	19.42	19.92	20.42
b1	-	2.00	-	L1	-	4.13	-
b2	-	3.00	-	P	3.50	3.60	3.70
c	0.55	0.60	0.75	P1	-	7.19	-
D	20.80	21.00	21.20	P2	-	2.50	-
D1	-	16.55	-	Q	-	5.80	-
D2	-	1.20	-	S	6.05	6.15	6.25
E	15.60	15.80	16.00	T	-	10.00	-
E1	-	13.30	-	U	-	6.20	-

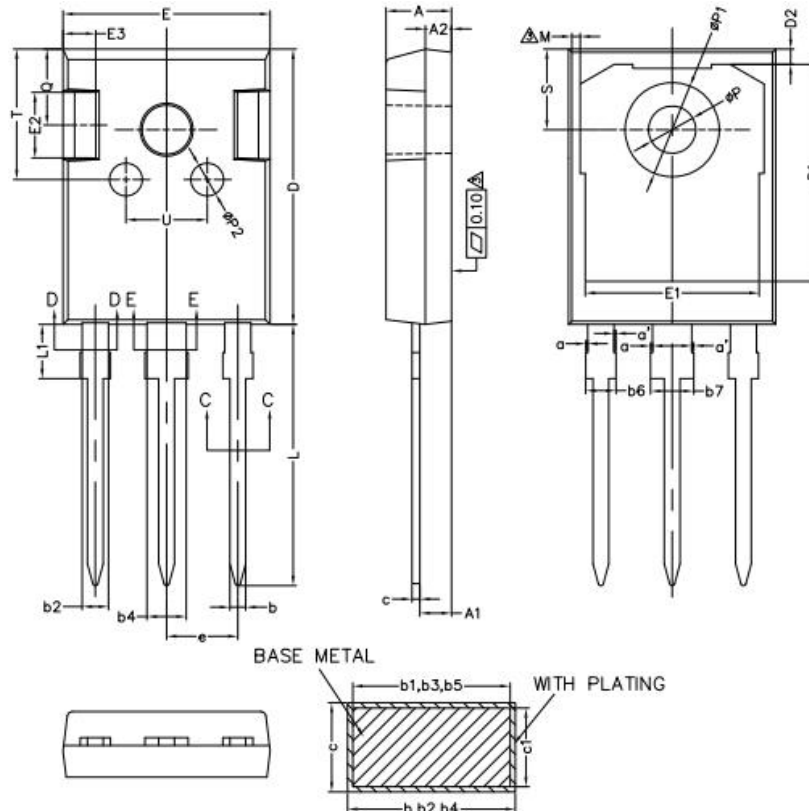
Mechanical Dimensions
TO-247 (Package2)
Unit: mm

Symbol	Dimensions (mm)			Symbol	Dimensions (mm)		
	Min.	Typ.	Max.		Min.	Typ.	Max.
A	4.90	5.00	5.10	D2	1.05	1.20	1.35
A1	2.31	2.41	2.51	E	15.70	15.80	15.90
A2	1.90	2.00	2.10	E1	13.10	13.30	13.50
a	0	-	0.15	E2	4.90	5.00	5.10
a'	0	-	0.15	E3	2.40	2.50	2.60
b	1.16	-	1.26	e	5.34	5.44	5.54
b1	1.15	1.20	1.22	L	19.80	19.92	20.10
b2	1.96	-	2.06	L1	3.95	4.13	4.30
b3	1.95	2.00	2.02	M	0.35	-	0.95
b4	2.96	-	3.06	P	3.50	3.60	3.70
b5	2.95	3.00	3.02	P1	7.00	-	7.40
b6	-	-	2.25	P2	2.40	2.50	2.60
b7	-	-	3.25	Q	5.60	-	6.00
c	0.59	-	0.66	S	6.05	6.15	6.25
c1	0.58	0.60	0.62	T	9.80	-	10.20
D	20.90	21.00	21.10	U	6.00	-	6.40
D1	16.25	16.55	16.85				

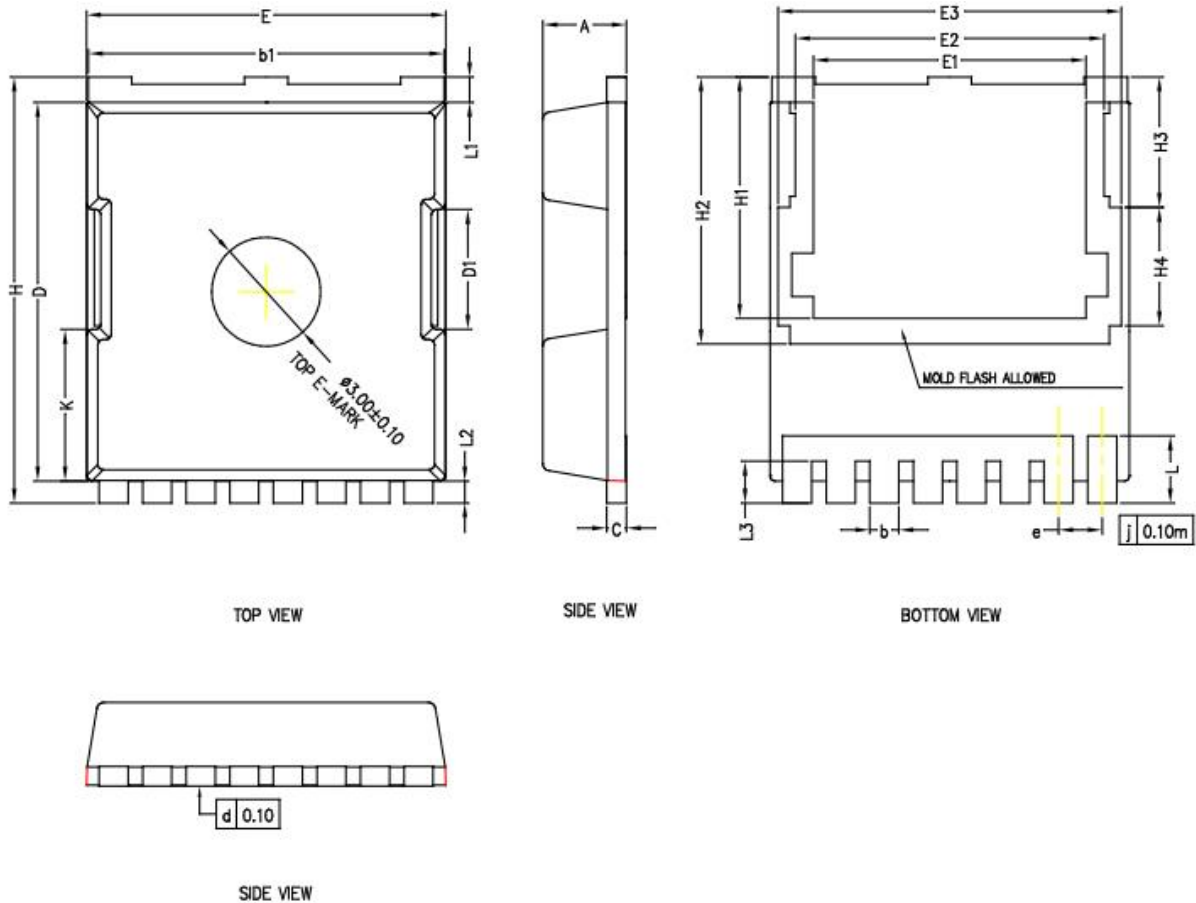
Mechanical Dimension
TOLL
Unit: mm

Symbol	Dimensions (mm)			Symbol	Dimensions (mm)		
	Min.	Typ.	Max.		Min.	Typ.	Max.
A	2.20	2.30	2.40	H	11.48	11.73	11.88
b	0.70	0.80	0.90	H1	6.55	6.65	6.75
b1	9.70	9.80	9.90	H2	7.20	7.35	7.50
c	0.40	0.50	0.60	H3	3.44	3.59	3.74
D	10.28	10.43	10.58	H4	3.11	3.26	3.41
D1	3.15	3.30	3.45	K	4.03	4.18	4.33
E	9.70	9.90	10.10	L	1.60	1.85	2.10
E1	7.35	7.50	7.65	L1	0.55	0.70	0.85
E2	8.35	8.50	8.65	L2	0.45	0.60	0.75
E3	9.31	9.46	9.61	L3	1.00	1.15	1.30
e	1.10	1.20	1.30				



Sanrise Technology Limited Company

<http://www.sanrise-tech.com>

IMPORTANT NOTICE

Shenzhen Sanrise Technology Co., LTD. reserves the right to make changes without further notice to any products or specifications herein. Shenzhen Sanrise Technology Co., LTD. does not assume any responsibility for use of any its products for any particular purpose, nor does Shenzhen Sanrise Technology Co., LTD. assume any liability arising out of the application or use of any its products or circuits. Shenzhen Sanrise Technology Co., LTD. does not convey any license under its patent rights or other rights nor the rights of others.

Main Site:

- Headquarter

Shenzhen Sanrise Technology Co., LTD.
A1206, Skyworth building, No. 008, gaoxinnan 1st Road,
Gaoxin District, Yuehai street,, Nanshan District, ShenZhen,
P.R.China
Tel: +86-755-22953335
Fax: +86-755-22916878

- Shanghai Office

Sanrise Technology Limited Company
Rm.401, Building B, No. 666, Zhangheng Road,
Zhangjiang Hi-Tech Park, Shanghai, P.R.China
Tel: +86-21-68825918