

General Description

The Sanrise SRT06N095L is a low voltage power MOSFET, fabricated using advanced split gate trench technology. The resulting device has extremely low on resistance, low gate charge and fast switching time, making it especially suitable for applications which require superior power density and synchronous rectification.

The SRT06N095L break down voltage is 60V and it has a high rugged avalanche characteristics. The SRT06N095L is available in PDFN5*6 and SOP-8 and TO-252 and PDFN3.3*3.3 packages.

Features

- Optimized for Power Application, esp. Synchronous Rectifier
- Ultra Low $R_{DS(ON)}$
 $R_{DS(ON_TYP)} = 8.0m\Omega, PDFN5*6 @ V_{GS} = 10V.$
 $R_{DS(ON_TYP)} = 8.5m\Omega, SOP8 @ V_{GS} = 10V.$
 $R_{DS(ON_TYP)} = 9.0m\Omega, TO-252 @ V_{GS} = 10V.$
 $R_{DS(ON_TYP)} = 8.5m\Omega, PDFN3.3*3.3 @ V_{GS} = 10V.$
- Ultra Low Gate Charge, $Q_g = 18.7nC$ typ.
- Fast switching capability
- Robust design with better EAS performance
- EMI Improved
- Non-automotive Qualified

Application

- PD
- Charger / Adapter
- DC/DC Converter
- Motor Driver

Symbol

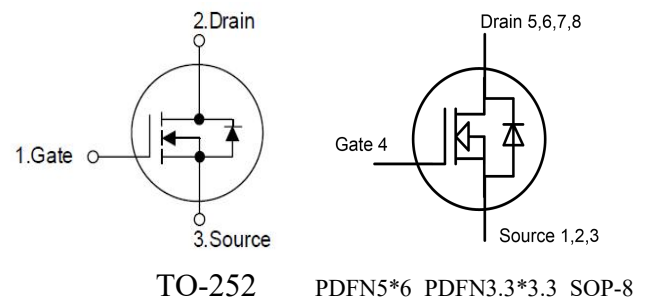

Figure 1 Symbol of SRT06N095L

Package Type

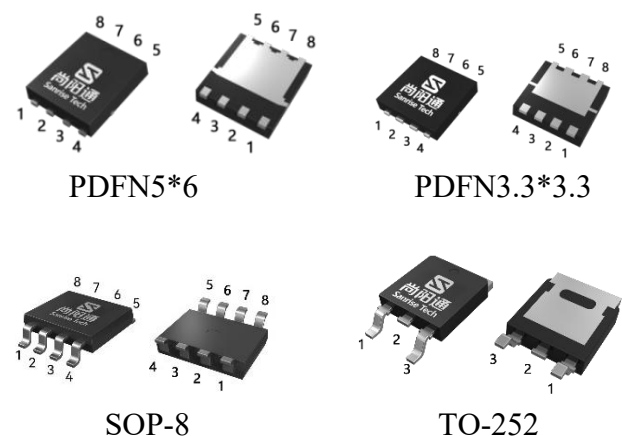
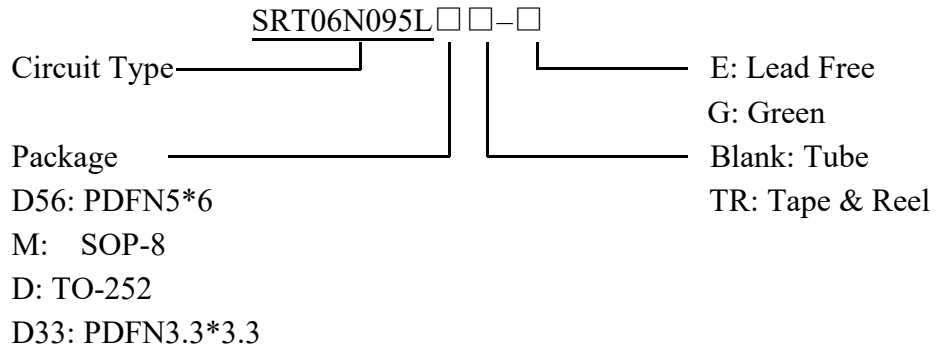

Figure 2 Package Type of SRT06N095L

Ordering Information

Package	Part Number	Marking ID	Packing Type
PDFN5*6	SRT06N095LD56TR-G	SRT06N095LD56G	Tape & Reel
SOP-8	SRT06N095LMTR-G	06N095LMG	Tape & Reel
TO-252	SRT06N095LDTR-G	SRT06N095LDG	Tape & Reel
PDFN3.3*3.3	SRT06N095LD33TR-G	SRT06N095LD33G	Tape & Reel

Absolute Maximum Ratings

Parameter		Symbol	Rating		Unit
Drain-Source Voltage		V_{DSS}	60		V
Gate-Source Voltage		V_{GSS}	±20		V
Continuous Drain Current, Package Limited	$T_C=25^{\circ}C$	I_D	PDFN5*6	44	A
	$T_L=25^{\circ}C$		SOP8	14	
	$T_C=25^{\circ}C$		TO-252	44	
	$T_C=25^{\circ}C$		PDFN3.3*3.3	42	
	$T_C=125^{\circ}C$		PDFN5*6	20	
	$T_L=125^{\circ}C$		SOP8	6.2	
	$T_C=125^{\circ}C$		TO-252	20	
	$T_C=125^{\circ}C$		PDFN3.3*3.3	19	
Continuous Drain Current, Silicon	$T_C=25^{\circ}C$		44		
Pulsed Drain Current (Note 2)		I_{DM}	PDFN5*6	176	A
			SOP8	56	
			TO-252	176	
			PDFN3.3*3.3	168	
Avalanche Energy, Single Pulse (Note 3)		E_{AS}	16		mJ
Avalanche Destructive Energy, Single Pulse (Note 4)		E_{AS_Limit}	100		mJ
Avalanche Energy, Repetitive (Note 2)		E_{AR}	0.1		mJ
Avalanche Current, Repetitive (Note 2)		I_{AR}	8.0		A
Continuous Diode Forward Current		I_S	44		A
Diode Pulse Current		I_{S_PULSE}	176		A
Max Power Dissipation		P_D	36.7		W
Operating Junction Temperature		T_J	150		°C
Storage Temperature		T_{STG}	-55 to 150		°C
Lead Temperature (Soldering, 10 sec)		T_{LEAD}	260		°C

Note:

- Absolute maximum ratings are those values beyond which the device could be permanently damaged. Absolute maximum ratings are stress ratings only and functional device operation is not implied.
- Repetitive Rating: Pulse width limited by maximum junction temperature
- $I_{AS}=8.0A$, $V_{DD}=20V$, $R_G=25\Omega$, Starting $T_J=25^{\circ}C$
- $I_{AS_Limit}=20A$, $V_{DD}=20V$, $R_G=25\Omega$, Starting $T_J=25^{\circ}C$

Thermal Resistance

Parameter		Symbol	Min	Typ	Max	Unit
Thermal Resistance, Junction-to-Case	PDFN5*6	R _{thJC}			3.4	°C/W
Thermal Resistance, Junction-to-Lead	SOP8	R _{thJL}			32	
Thermal Resistance, Junction-to-Case	TO-252	R _{thJC}			3.2	
Thermal Resistance, Junction-to-Case	PDFN3.3*3.3	R _{thJC}			3.4	
Thermal Resistance, Junction-to-Ambient	PDFN5*6	R _{thJA}			50	
Thermal Resistance, Junction-to-Ambient	SOP8	R _{thJA}			80	
Thermal Resistance, Junction-to-Ambient	TO-252	R _{thJA}			62	
Thermal Resistance, Junction-to-Ambient	PDFN3.3*3.3	R _{thJA}			50	

Electrical Characteristics
 $T_J = 25^\circ\text{C}$, unless otherwise specified.

Parameter	Symbol	Test Conditions	Min	Typ	Max	Unit
Statistic Characteristics						
Drain-Source Breakdown Voltage	BV_{DSS}	$V_{GS}=0V, I_D=250\mu A$	60			V
Zero Gate Voltage Drain Current	I_{DSS}	$V_{DS}=60V, V_{GS}=0V$			1	μA
Gate-Body Leakage Current	Forward	$I_{GSSF}, V_{GS}=20V, V_{DS}=0V$			100	nA
	Reverse	$I_{GSSR}, V_{GS}=-20V, V_{DS}=0V$			-100	
Gate Threshold Voltage	$V_{GS(TH)}$	$V_{DS}=V_{GS}, I_D=0.25mA$	1.2	1.7	2.4	V
Static Drain-Source On-Resistance	PDFN5*6	$R_{DS(ON)}, V_{GS}=10V, I_D=20A$		8.0	9.5	mΩ
	SOP8			8.5	10.0	
	TO-252			9.0	10.5	
	PDFN3.3*3.3			8.5	10.0	
	PDFN5*6	$R_{DS(ON)}, V_{GS}=4.5V, I_D=10A$		10.3	15	
	SOP8			10.8	15	
	TO-252			11.3	15	
	PDFN3.3*3.3			10.8	15	
Gate Resistance	R_G	$f=1MHz, \text{Open Drain}$		1.4		Ω
Dynamic Characteristics						
Input Capacitance	C_{ISS}	$V_{DS}=30V, V_{GS}=0V, f=1MHz$		1.08		nF
Output Capacitance	C_{OSS}			300		pF
Reverse Transfer Capacitance	C_{RSS}			13		pF
Effective output capacitance, energy related ^{NOTE5}	$C_{O(er)}$	$V_{GS}=0V, V_{DS}=0\dots 48V$		300		pF
Effective output capacitance, time related ^{NOTE6}	$C_{O(tr)}$			420		
Turn-on Delay Time	$t_{d(on)}$	$V_{DD}=30V, I_D=20A, R_G=1.6\Omega, V_{GS}=10V$		5		ns
Rise Time	t_r			4		
Turn-off Delay Time	$t_{d(off)}$			18		
Fall Time	t_f			5		
Gate Charge Characteristics						
Gate to Source Charge	Q_{gs}	$V_{DD}=30V, I_D=20A, V_{GS}=0 \text{ to } 10V$		3.1		nC
Gate to Drain Charge	Q_{gd}			3.4		
Gate Charge Total	Q_g			18.7		
Gate Plateau Voltage	$V_{plateau}$			2.9		V
Gate Charge Total, sync FET	Q_g	$V_{DD}=0.1V, V_{GS}=0 \text{ to } 10V$		16.4		nC
Reverse Diode Characteristics						
Drain-Source Diode Forward Voltage	V_{SD}	$V_{GS}=0V, I_{SD}=20A$		0.87	1.0	V
Reverse Recovery Time	t_{rr}	$V_R=30V, I_F=20A, dI_F/dt=100A/\mu s$		23		ns
Reverse Recovery Charge	Q_{rr}			17		nC
Peak Reverse Recovery Current	I_{rrm}			1.5		A

Note:

 5. $C_{O(er)}$ is a fixed capacitance that gives the same stored energy as C_{OSS} while V_{DS} is rising from 0 to 48V

 6. $C_{O(tr)}$ is a fixed capacitance that gives the same charging time as C_{OSS} while V_{DS} is rising from 0 to 48V



Sanrise Technology Limited Company

<http://www.sanrise-tech.com>

IMPORTANT NOTICE

Shenzhen Sanrise Technology Co., LTD. reserves the right to make changes without further notice to any products or specifications herein. Shenzhen Sanrise Technology Co., LTD. does not assume any responsibility for use of any its products for any particular purpose, nor does Shenzhen Sanrise Technology Co., LTD. assume any liability arising out of the application or use of any its products or circuits. Shenzhen Sanrise Technology Co., LTD. does not convey any license under its patent rights or other rights nor the rights of others.

Main Site:

- Headquarter

Shenzhen Sanrise Technology Co., LTD.

A1206, Skyworth building, No. 008, gaoxinnan 1st Road,
Gaoxin District, Yuehai street,, Nanshan District, ShenZhen,
P.R.China

Tel: +86-755-22953335

Fax: +86-755-22916878

- Shanghai Office

Sanrise Technology Limited Company

Rm.401, Building B, No. 666, Zhangheng Road,
Zhangjiang Hi-Tech Park, Shanghai, P.R.China

Tel: +86-21-68825918